

1		2		3		4		5		6	
Document No.	QR4-700-T-003	REV.	A/0	REV.	DESCRIPTION	REVISOR	DATE	APPROVED			
		0		M.Hao	03.03.2014	David					

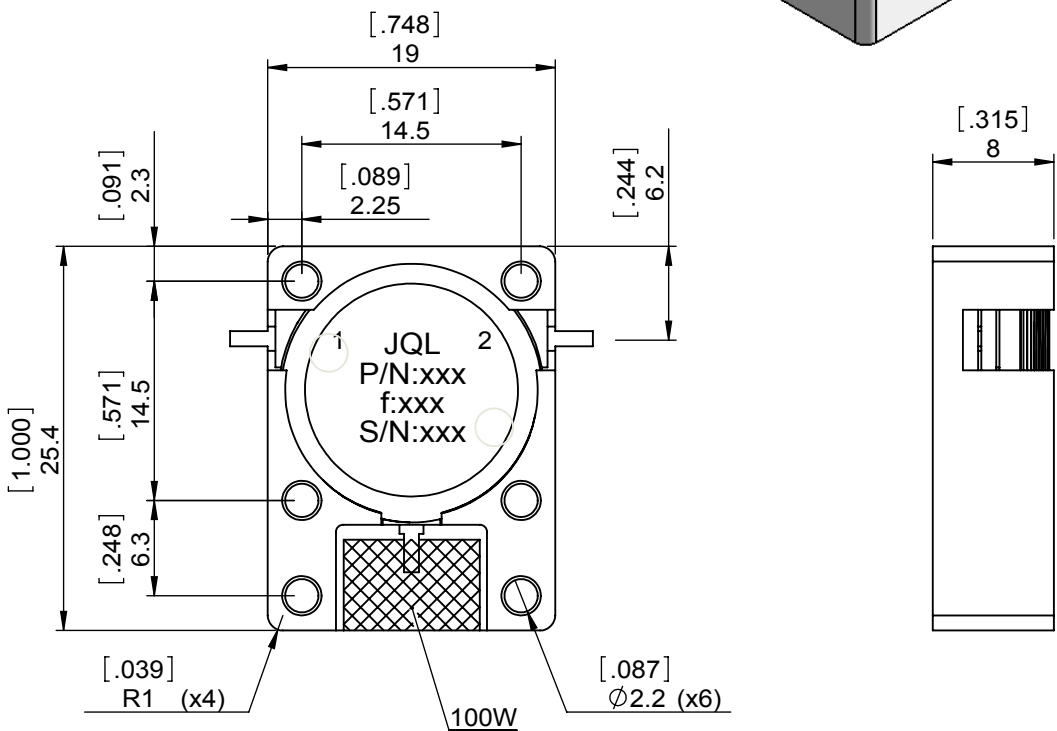
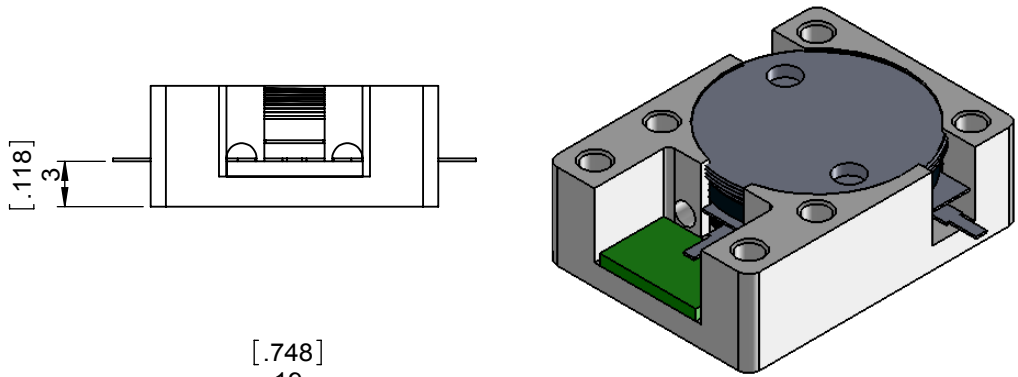

SPECIFICATIONS	
Part's Number	JID0890T0925SM10
Frequency(GHz)	0.890~0.925
Direction	CW
Insertion Loss(dB)MAX	0.30
Isolation(dB)MIN	21.0
Return Loss(dB)MIN	20.0
3rd IMD(dBc)MAX	-70dBc @ 2x50W
Power FWD/REV/PK(Watt)	100/100/-
Operating Temperature(°C)	-40~+85
Storage Temperature(°C)	--
2nd/3rd Harmonic(dBc)	-
Termination/Attenuator(Watt/dB)	100
Tab(W×LG×THK)(mm[Inch])	1.0[.039]X2.0[.079]X0.20[.008]
Additional Notes	-

JQL JQL Electronic Inc 500 Lake Cook Road, Suite 350 Deerfield, IL 60015, USA Tel: 1(888)236-9828 Fax: 1(888)823-2902

MATERIAL: STEEL	DWG NO: JID0890T0925SM10			
SURFACE TREATMENT: NICKEL PLATING	DWG BY:	M.Hao	03.03.2014	SACLE
	CHK'D BY:			
DESCRIPTION: DROP-IN ISOLATOR	APPV'D BY:			2:1
	Unit:	Tolerance:	The First:	A4
	mm[inch]	Liner: ±0.25 Anguar: ±0.5°		

RoHS COMPLIANCE This document is the property of JQL Electronic Inc. It cannot be copied, duplicated, used for manufacturing purposes or communicated to third party as a whole or partly, without the written consent of JQL Electronic Inc.