

1		2		3		4		5		6			
Document No.	QR4-700-T-003	REV.	A/0	REV.	0	DESCRIPTION		REVISOR	Hu.Jiang	DATE	06.04.2019	APPROVED	HC.Qiu

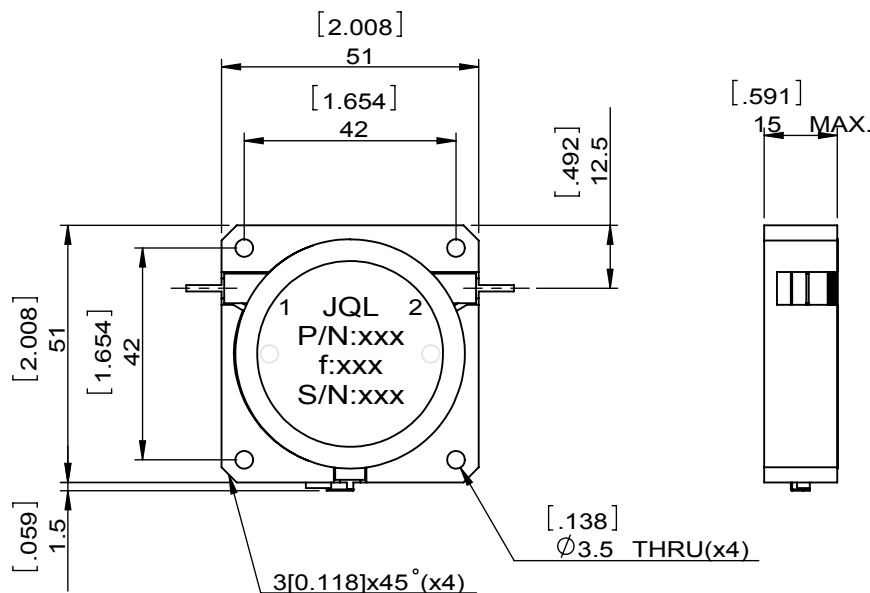
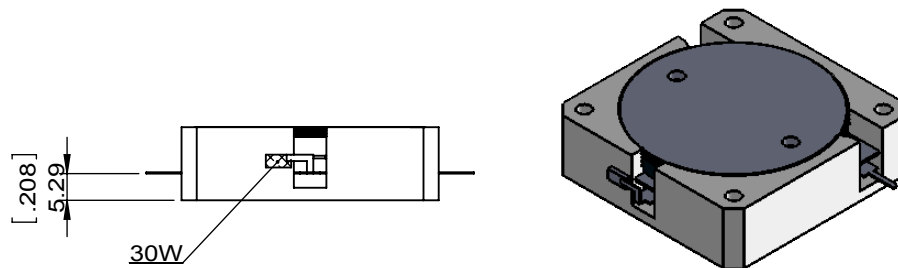

SPECIFICATIONS	
Part's Number	JID0900T1800UM0
Frequency(GHz)	0.900~1.800
Direction	CW
Insertion Loss(dB)MAX	0.7
Isolation(dB)MIN	14.0
Return Loss(dB)MIN	14.0
3rd IMD(dBc)MAX	-
Power FWD/REV/PK(Watt)	5/1/-
Operating Temperature(°C)	+10~+45
Storage Temperature(°C)	-
2nd/3rd Harmonic(dBc)	-
Termination/Attenuator(Watt/dB)	30
Tab(W×LG×THK)(mm[Inch])	1.27[0.050]x4[0.157]x0.2[0.008]
Additional Notes	-

JQL **JQL Electronic Inc** 500 Lake Cook Road, Suite 350 Deerfield, IL 60015, USA Tel: 1(888)236-9828 Fax: 1(888)823-2902

MATERIAL: STEEL	DWG NO: JID0900T1800UM0			
SURFACE TREATMENT: NICKEL PLATING	DWG BY:	Hu.Jiang	06.04.2019	SACLE
DESCRIPTION: DROP IN ISOLATOR	CHK'D BY:			
	APPV'D BY:			2:3
	Unit: mm[inch]	Tolerance: Liner: ±0.25 Anguar: ±0.5°	The First:	A4



This document is the property of JQL Electronic Inc. It cannot be copied, duplicated, used for manufacturing purposes or communicated to third party as a whole or partly, without the written consent of JQL Electronic Inc.