

1		2		3		4		5		6			
Document No.	QR4-700-T-003	REV.	A/0	REV.	0	DESCRIPTION		REVISOR	JP.Yang	DATE	07.24.2013	APPROVED	David

A

A

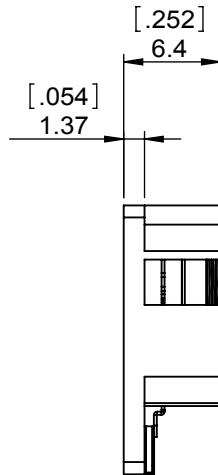
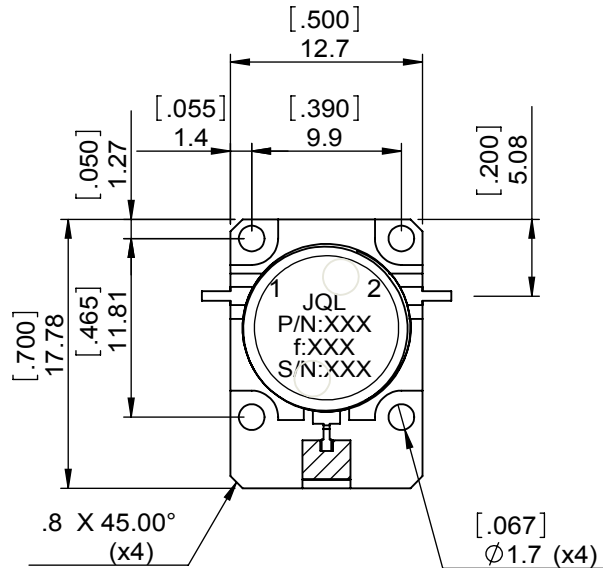
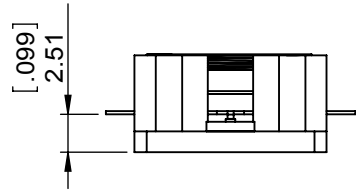
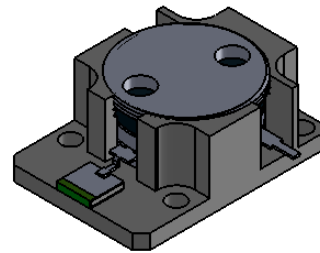

B

B

C

C

D

D

SPECIFICATIONS	
Part's Number	JID10K15T13K25VM1
Frequency(GHz)	10.15~13.25
Direction	CW
Insertion Loss(dB)MAX	0.50
Isolation(dB)MIN	20.0
Return Loss(dB)MIN	20.0
3rd IMD(dBc)MAX	-
Power FWD/REV/PK(Watt)	10/10/-
Operating Temperature(°C)	-40~+85
Storage Temperature(°C)	-
2nd/3rd Harmonic(dBc)	-
Termination/Attenuator(Watt/dB)	-
Tab(W×LG×THK)(mm[Inch])	0.635[.030]X1.9[.070]X0.15[.010]
Additional Notes	-

JQL JQL Electronic Inc 500 Lake Cook Road, Suite 350 Deerfield, IL 60015, USA Tel: 1(888)236-9828 Fax: 1(888)823-2902

MATERIAL: STEEL	DWG NO: JID10K15T13K25VM1			
SURFACE TREATMENT: NICKEL PLATING	DWG BY:	JP.Yang	07.24.2013	SACLE
	CHK'D BY:			
DESCRIPTION: DROP-IN ISOLATOR	APPV'D BY:			2:1
	Unit: mm[inch]	Tolerance: Liner: ±0.25 Anguar: ±0.5°	The First:	A4



This document is the property of JQL Electronic Inc. It cannot be copied, duplicated, used for manufacturing purposes or communicated to third party as a whole or partly, without the written consent of JQL Electronic Inc.