

Stock Number

REV.	DESCRIPTION	REVISOR	DATE	APPROVE
0		XG	01.01.10	CH

0.64[.025]w X1.78[.07]±0.51[.02] L
X0.13[.005]±0.03[.001]THK

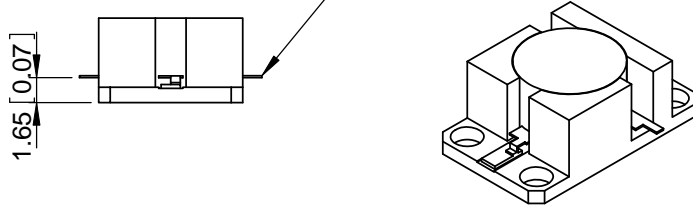

SPECIFICATION

Part's Number: JID10K5T10K9JM2
 Frequency: 10/5~10.9GHz
 Insertion Loss: 0.40dB MAX
 Isolation: 20.0dBMIN
 VSWR: 1.25dB MAX
 PWR FWD PK/AVG: 25W/2.5W
 TERMINATION: 2W
 Temperature: -40°C~ 85°C

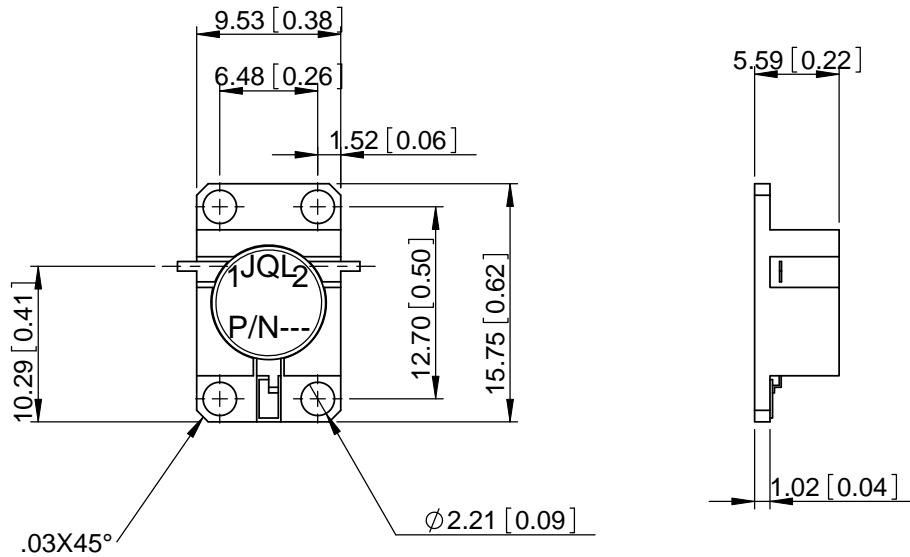

This document is the property of JQL Electronic Inc.
 It cannot be copied, duplicated, used for manufacturing purposes
 or communicated to third party as a whole or partly,
 without the written consent of JQL Electronic Inc.

JQL JQL Electronic Inc		500 Lake Cook Road, Suite 350 Deerfield, IL 60015, USA		Tel : 1(888)236-9828 Fax: 1(630)823-2902															
MATERIAL:	DWG NO. JID10K5T10K9JM2																		
SURFACE TREATMENT:	<table border="1"> <thead> <tr> <th></th> <th>NAME</th> <th>DATE</th> <th>SCALE:</th> </tr> </thead> <tbody> <tr> <td>DWG BY:</td> <td>LS</td> <td>08.25.11</td> <td rowspan="3">1:1</td> </tr> <tr> <td>CHK'D BY:</td> <td>MH</td> <td>08.25.11</td> </tr> <tr> <td>APPV'D BY:</td> <td>CH</td> <td>08.25.11</td> </tr> </tbody> </table>						NAME	DATE	SCALE:	DWG BY:	LS	08.25.11	1:1	CHK'D BY:	MH	08.25.11	APPV'D BY:	CH	08.25.11
	NAME	DATE	SCALE:																
DWG BY:	LS	08.25.11	1:1																
CHK'D BY:	MH	08.25.11																	
APPV'D BY:	CH	08.25.11																	
DESCRIPTION: DROP-IN ISOLATOR	Unit: mm		2 PLACE DECIMALS: ± 0.25 3 Dimension between hole: ± 0.127 Angular: ±0.5°		Type Of Projection 														

WEIGHT: