

1		2		3		4		5		6	
Document No.	QR4-700-T-003	REV.	A/0	REV.	DESCRIPTION	REVISOR	DATE	APPROVED			
		0		ZC.Wu	09.03.2014	David					

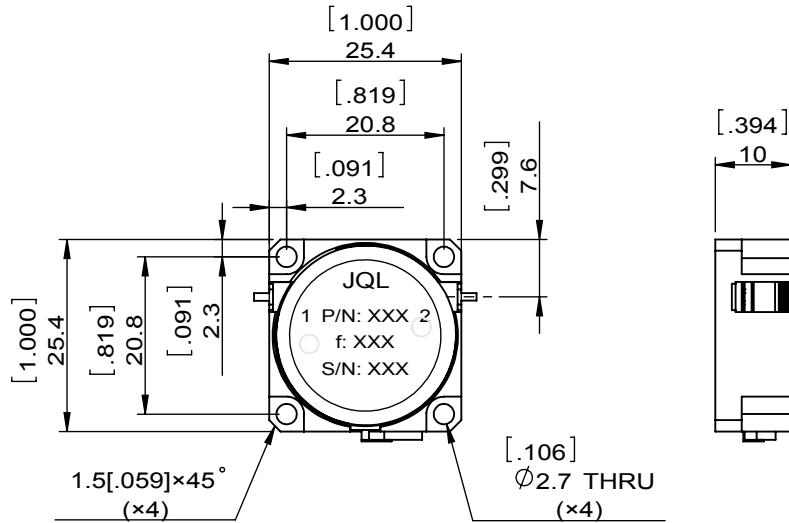

SPECIFICATIONS	
Part's Number	JID1450T1850M3
Frequency(GHz)	1.450~1.850
Direction	CW
Insertion Loss(dB)MAX	0.50
Isolation(dB)MIN	18.0
Return Loss(dB)MIN	18.0
3rd IMD(dBc)MAX	-
Power FWD/REV/PK(Watt)	30/30/-
Operating Temperature(°C)	-40~+85
Storage Temperature(°C)	-
2nd/3rd Harmonic(dBc)	-
Termination/Attenuator(Watt/dB)	30W
Tab(W×LG×THK)(mm[Inch])	1.1[0.043]x2.0[0.079]x0.2[0.008]
Additional Notes	-

<b>JQL</b> JQL Electronic Inc				
<b>MATERIAL:</b> STEEL		<b>DWG NO:</b> JID1450T1850M3		
<b>SURFACE TREATMENT:</b> NICKEL PLATING		DWG BY:	ZC.Wu	09.03.2014
<b>DESCRIPTION:</b> DROP-IN ISOLATOR		CHK'D BY:		SCALE
		APPV'D BY:		1:1
		Unit: mm[inch]	Tolerance: Liner: ±0.25 Anguar: ±0.5°	The First: 
				A4

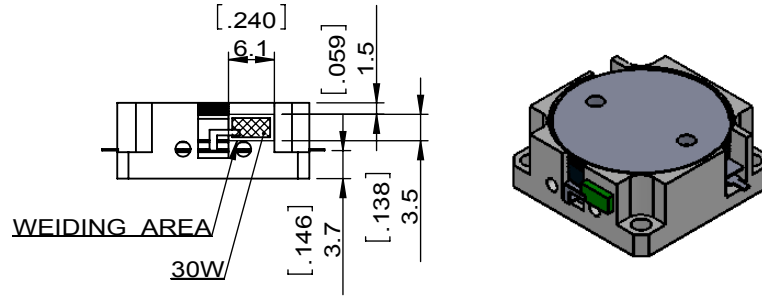

This document is the property of JQL Electronic Inc. It cannot be copied, duplicated, used for manufacturing purposes or communicated to third party as a whole or partly, without the written consent of JQL Electronic Inc.