

1		2		3		4		5		6	
Document No.	QR4-700-T-003	REV.	A/0	REV.	DESCRIPTION	REVISOR	DATE	APPROVED			
		0		M.Hao	10.23.2013	David					

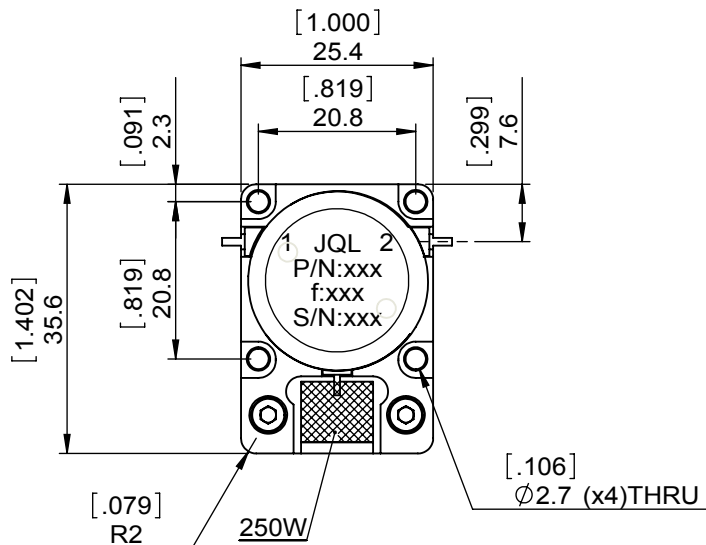
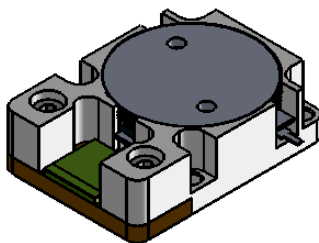
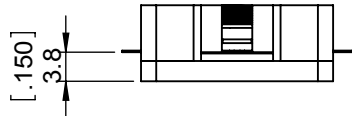

SPECIFICATIONS	
Part's Number	JID1700T2200M20
Frequency(GHz)	1.700~2.200
Direction	CW
Insertion Loss(dB)MAX	0.40
Isolation(dB)MIN	20.0
Return Loss(dB)MIN	20.0
3rd IMD(dBc)MAX	-
Power FWD/REV/PK(Watt)	200/200/-
Operating Temperature(°C)	-40~+85
Storage Temperature(°C)	-
2nd/3rd Harmonic(dBc)	-
Termination/Attenuator(Watt/dB)	250W
Tab(W×LG×THK)(mm[Inch])	1.1[.433]WX2.5[.098]LGX0.2[.008]THK
Additional Notes	-

JQL **JQL Electronic Inc** 500 Lake Cook Road, Suite 350 Deerfield, IL 60015, USA Tel: 1(888)236-9828 Fax: 1(888)823-2902

MATERIAL: STEEL	DWG NO: JID1700T2200M20			
SURFACE TREATMENT: NICKEL PLATING	DWG BY:	M.Hao	10.23.2013	SACLE
	CHK'D BY:			
DESCRIPTION: DROP IN ISOLATOR	APPV'D BY:			1:1
	Unit: mm[inch]	Tolerance: Liner: ±0.25 Anguar: ±0.5°	The First:	A4



This document is the property of JQL Electronic Inc. It cannot be copied, duplicated, used for manufacturing purposes or communicated to third party as a whole or partly, without the written consent of JQL Electronic Inc.