

| | | | | | | | | | | | |
|--------------|---------------|------|-----|-------|-------------|---------|------|----------|--|---|--|
| 1 | | 2 | | 3 | | 4 | | 5 | | 6 | |
| Document No. | QR4-700-T-003 | REV. | A/0 | REV. | DESCRIPTION | REVISOR | DATE | APPROVED | | | |
| | | 0 | | M.Hao | 03.03.2014 | David | | | | | |

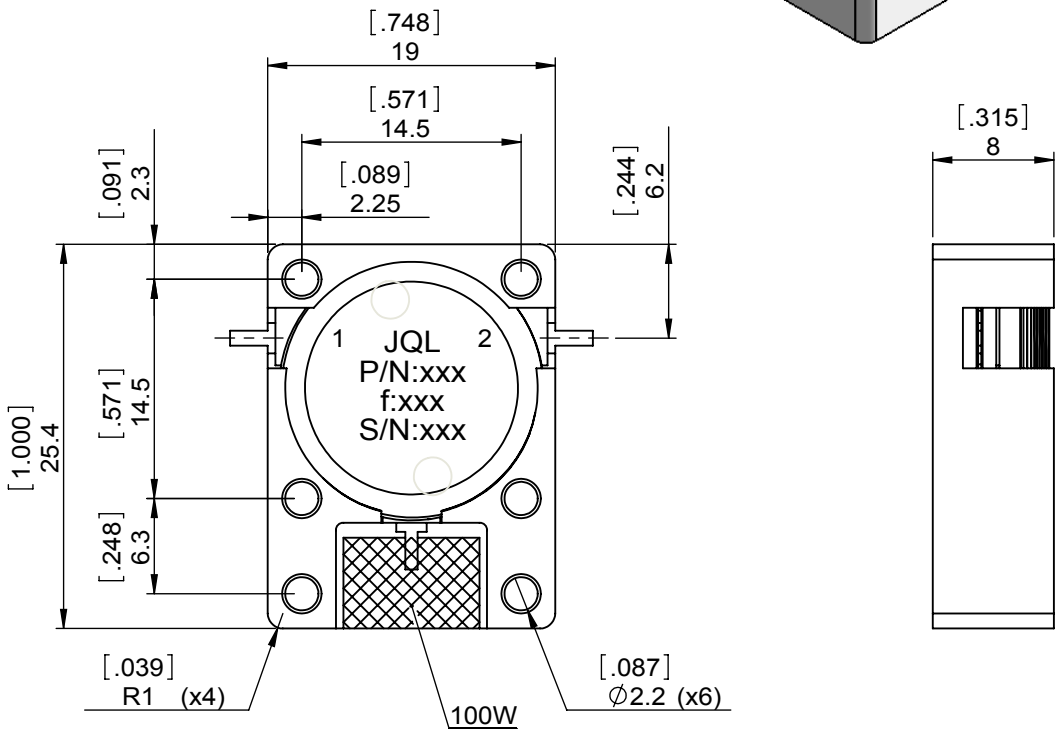
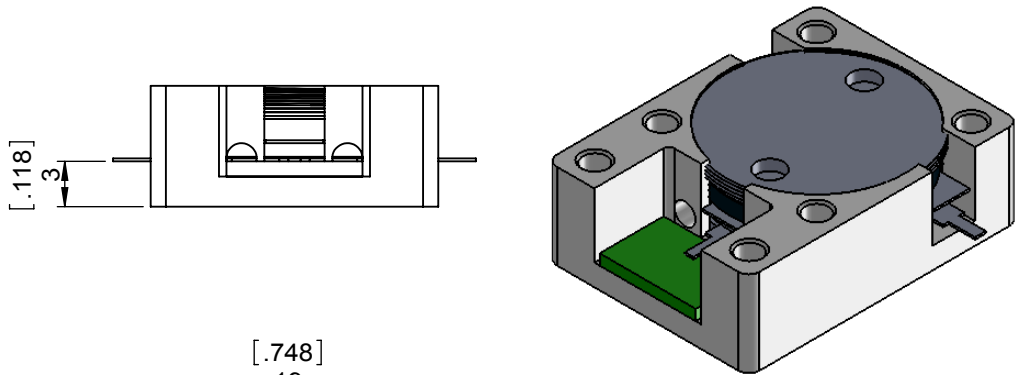

| SPECIFICATIONS | |
|---------------------------------|--------------------------------|
| Part's Number | JID2110T2170SM10 |
| Frequency(GHz) | 2.110~2.170 |
| Direction | CW |
| Insertion Loss(dB)MAX | 0.22 |
| Isolation(dB)MIN | 22.0 |
| Return Loss(dB)MIN | 22.0 |
| 3rd IMD(dBc)MAX | -75@2x100W |
| Power FWD/REV/PK(Watt) | 100/100/- |
| Operating Temperature(°C) | -40~+85 |
| Storage Temperature(°C) | - |
| 2nd/3rd Harmonic(dBc) | - |
| Termination/Attenuator(Watt/dB) | 100 |
| Tab(W×LG×THK)(mm[Inch]) | 1.0[.039]X2.0[.079]X0.20[.008] |
| Additional Notes | - |

JQL JQL Electronic Inc 500 Lake Cook Road, Suite 350 Deerfield, IL 60015, USA Tel: 1(888)236-9828 Fax: 1(888)823-2902

| | | | | |
|---|------------------------------------|---|------------|-------|
| MATERIAL: STEEL | DWG NO: JID2110T2170SM10 | | | |
| SURFACE TREATMENT: NICKEL PLATING | DWG BY: | M.Hao | 03.03.2014 | SACLE |
| | CHK'D BY: | | | |
| DESCRIPTION: DROP IN ISOLATOR | APPV'D BY: | | | 2:1 |
| | Unit: mm[inch] | Tolerance: Liner: ±0.25 Anguar: ±0.5° | The First: | A4 |

RoHS COMPLIANCE This document is the property of JQL Electronic Inc. It cannot be copied, duplicated, used for manufacturing purposes or communicated to third party as a whole or partly, without the written consent of JQL Electronic Inc.