

1		2		3		4		5		6	
Document No.	QR4-700-T-003	REV.	A/0	REV.	DESCRIPTION	REVISOR	DATE	APPROVED			
				0		M.Hao	10.14.2013	David			

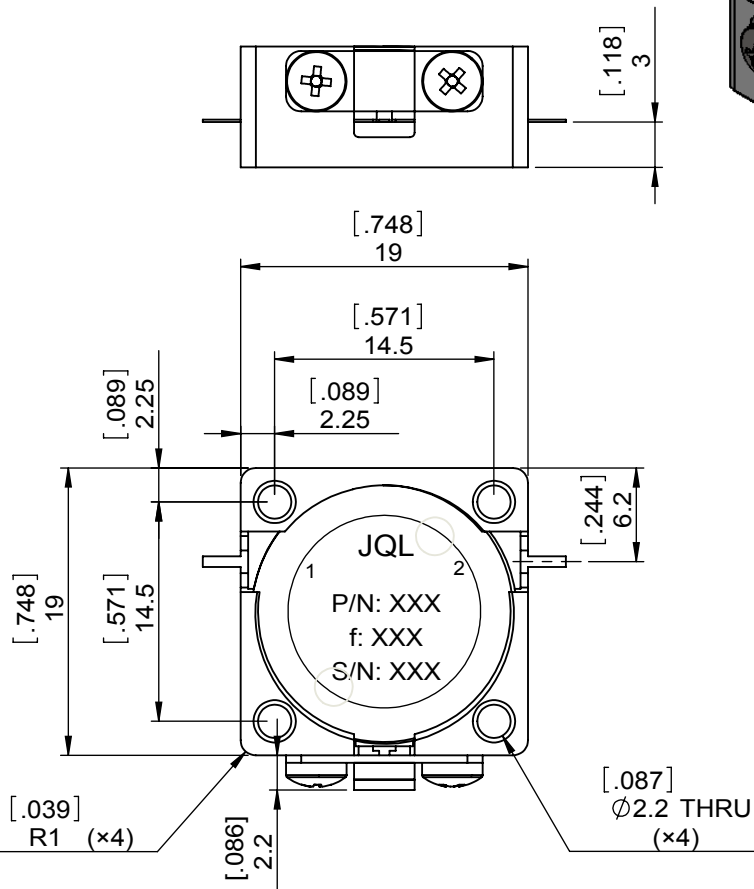
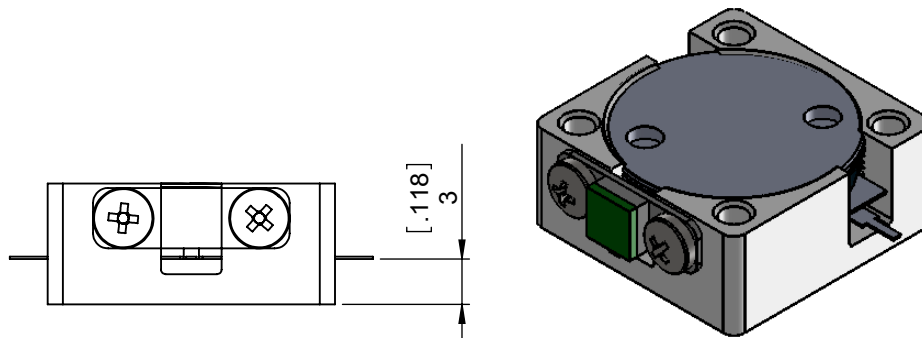

SPECIFICATIONS	
Part's Number	JID2200T2500SM1
Frequency(GHz)	2.200~2.500
Direction	CW
Insertion Loss(dB)MAX	0.40
Isolation(dB)MIN	20.0
Return Loss(dB)MIN	19.0
3rd IMD(dBc)MAX	-
Power FWD/REV/PK(Watt)	20/10/-
Operating Temperature(°C)	-40~+85
Storage Temperature(°C)	-
2nd/3rd Harmonic(dBc)	-
Termination/Attenuator(Watt/dB)	10
Tab(W×LG×THK)(mm[Inch])	0.6[0.024]×2.5[0.098]×0.2[0.008]
Additional Notes	-

**JQL** JQL Electronic Inc 500 Lake Cook Road, Suite 350 Deerfield, IL 60015, USA Tel: 1(888)236-9828 Fax: 1(888)823-2902

<b>MATERIAL:</b> STEEL	<b>DWG NO:</b> JID2200T2500SM1			
<b>SURFACE TREATMENT:</b> NICKEL PLATING	DWG BY:	M.Hao	10.14.2013	SACLE
	CHK'D BY:			
<b>DESCRIPTION:</b> DROP-IN ISOLATOR	APPV'D BY:			2:1
	Unit:	Tolerance:	The First:	A4
	mm[inch]	Liner: ±0.25 Anguar: ±0.5°		



This document is the property of JQL Electronic Inc. It cannot be copied, duplicated, used for manufacturing purposes or communicated to third party as a whole or partly, without the written consent of JQL Electronic Inc.

WEIGHT:

SHEET 1 OF 1