

1		2		3		4		5		6	
Document No.	QR4-700-T-003	REV.	A/0	REV.	DESCRIPTION	REVISOR	DATE	APPROVED			
				0		M.Hao	07.25.2013	David			

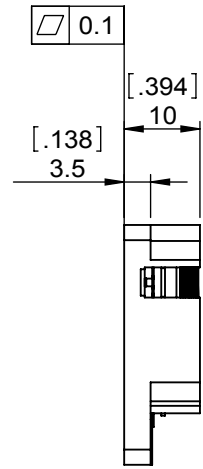
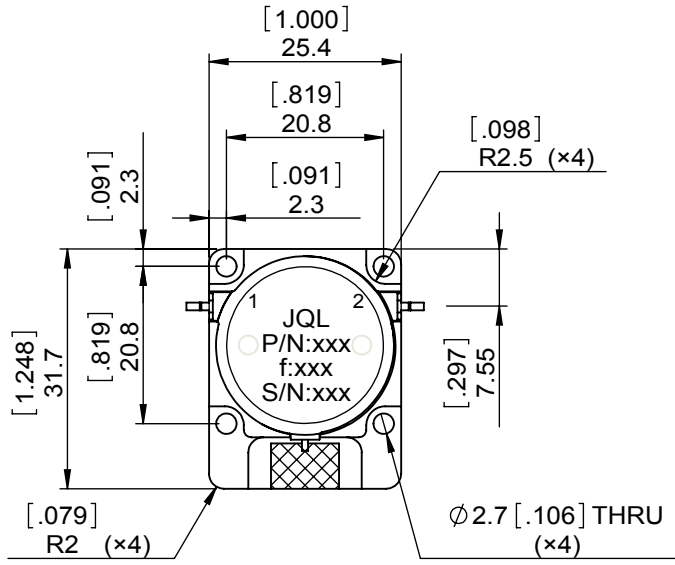
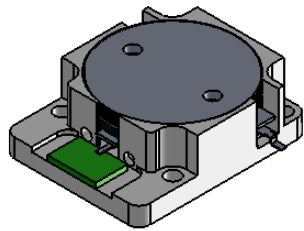
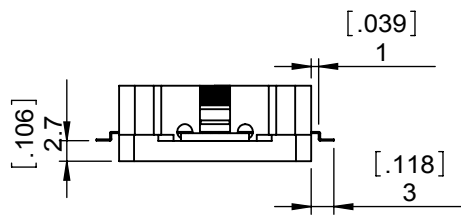

SPECIFICATIONS	
Part's Number	JID2290T2410M6
Frequency(GHz)	2.290~2.410
Direction	CW
Insertion Loss(dB)MAX	0.20
Isolation(dB)MIN	20.0
Return Loss(dB)MIN	20.0
3rd IMD(dBc)MAX	80dBc @2x45dBm
Power FWD/REV/PK(Watt)	90/60/400
Operating Temperature(°C)	-40~+110
Storage Temperature(°C)	-
2nd/3rd Harmonic(dBc)	-
Termination/Attenuator(Watt/dB)	100
Tab(W×LG×THK)(mm[Inch])	1.0[.039]×3.0[.118]×0.2[.008]
Additional Notes	-

JQL JQL Electronic Inc 500 Lake Cook Road, Suite 350 Deerfield, IL 60015, USA Tel: 1(888)236-9828 Fax: 1(888)823-2902

MATERIAL: STEEL	DWG NO: JID2290T2410M6			
SURFACE TREATMENT: NICKEL PLATING	DWG BY:	M.Hao	07.25.2013	SACLE
	CHK'D BY:			
DESCRIPTION: DROP-IN ISOLATOR	APPV'D BY:			1:1
	Unit:	Tolerance:	The First:	A4
	mm[inch]	Liner: ±0.25 Anguar: ±0.5°		

RoHS COMPLIANCE This document is the property of JQL Electronic Inc. It cannot be copied, duplicated, used for manufacturing purposes or communicated to third party as a whole or partly, without the written consent of JQL Electronic Inc.