

1		2		3		4		5		6	
Document No.	QR4-700-T-003	REV.	A/0	REV.	DESCRIPTION	REVISOR	DATE	APPROVED			
		0		ZC.Wu	12.30.2014	David					

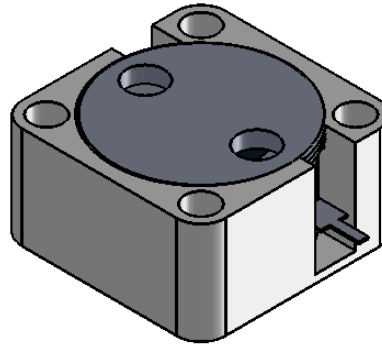

SPECIFICATIONS	
Part's Number	JID34K0T36K0VM0
Frequency(GHz)	34.000~36.000
Direction	CW
Insertion Loss(dB)MAX	1.5
Isolation(dB)MIN	18.0
Return Loss(dB)MIN	17.7
3rd IMD(dBc)MAX	-
Power FWD/REV/PK(Watt)	0.5/-/-
Operating Temperature(°C)	-
Storage Temperature(°C)	-
2nd/3rd Harmonic(dBc)	-
Termination/Attenuator(Watt/dB)	-
Tab(W×LG×THK)(mm[Inch])	0.64[0.025]x1.78[0.07]x0.13[0.005]
Additional Notes	-

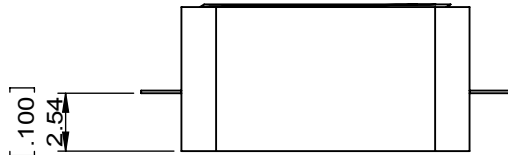
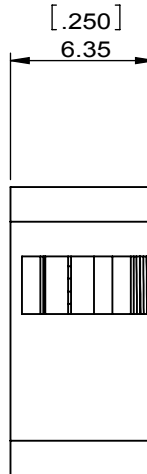
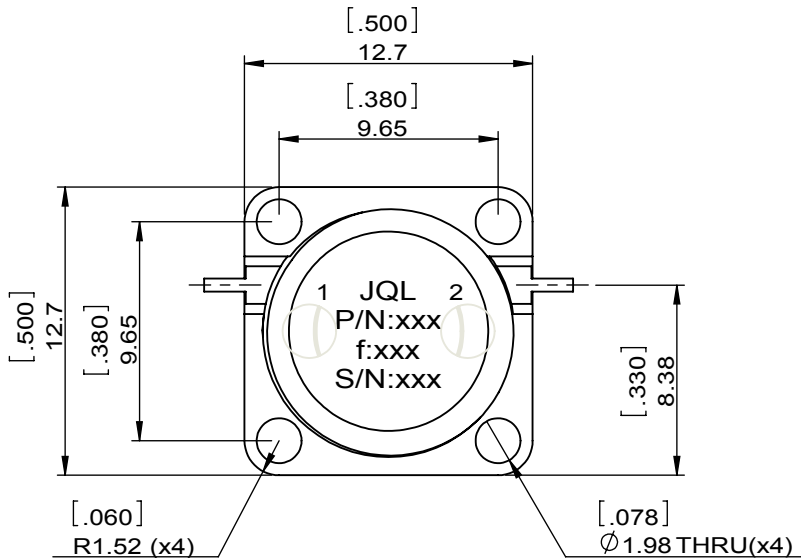

This document is the property of JQL Electronic Inc. It cannot be copied, duplicated, used for manufacturing purposes or communicated to third party as a whole or partly, without the written consent of JQL Electronic Inc.

JQL JQL Electronic Inc				
MATERIAL: STEEL		DWG NO: JID34K0T36K0VM0		
SURFACE TREATMENT: NICKEL PLATING		DWG BY:	ZC.Wu	12.30.2014
DESCRIPTION: DROP-IN ISOLATOR		CHK'D BY:		SCALE
		APPV'D BY:		3:1
		Unit: mm[inch]	Tolerance: Liner: ±0.25 Anguar: ±0.5°	The First:
				A4