

|              |               |      |     |      |             |          |            |          |  |   |  |
|--------------|---------------|------|-----|------|-------------|----------|------------|----------|--|---|--|
| 1            |               | 2    |     | 3    |             | 4        |            | 5        |  | 6 |  |
| Document No. | QR4-700-T-003 | REV. | A/0 | REV. | DESCRIPTION | REVISOR  | DATE       | APPROVED |  |   |  |
|              |               |      |     | 0    |             | LJ.Zhang | 03.25.2014 | David    |  |   |  |

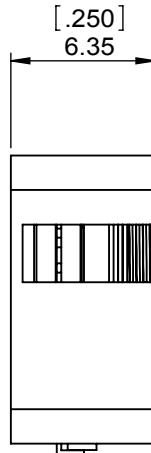
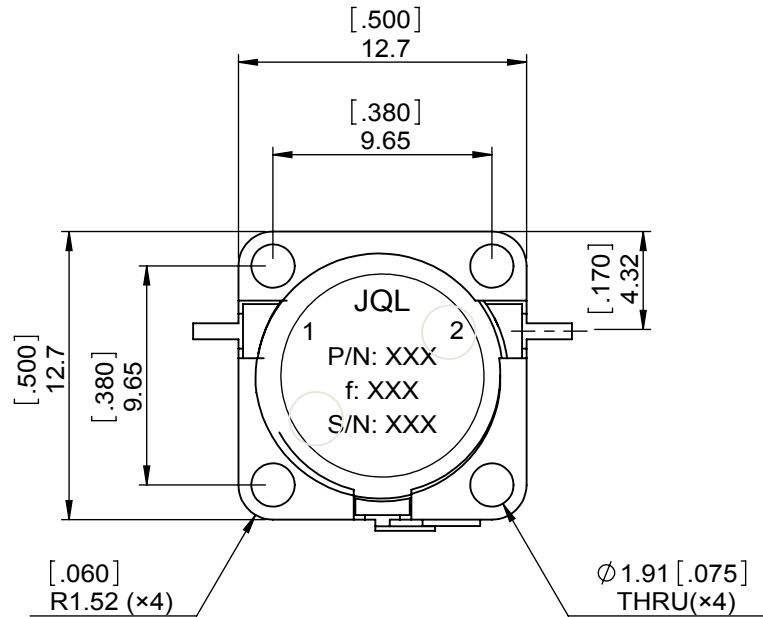
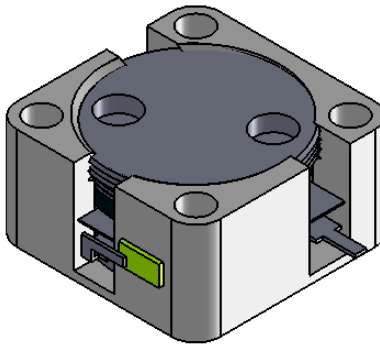
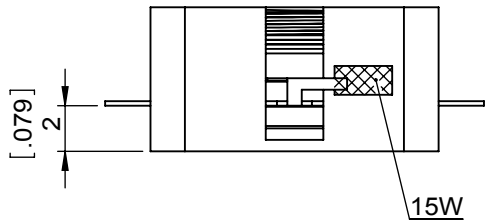

| SPECIFICATIONS                  |                                |
|---------------------------------|--------------------------------|
| Part's Number                   | JID4000T5000VM0                |
| Frequency(GHz)                  | 4.000~4.800                    |
| Direction                       | CW                             |
| Insertion Loss(dB)MAX           | 0.50                           |
| Isolation(dB)MIN                | 20.0                           |
| Return Loss(dB)MIN              | 20.0                           |
| 3rd IMD(dBc)MAX                 | -                              |
| Power FWD/REV/PK(Watt)          | 30/10/-                        |
| Operating Temperature(°C)       | 0~+60                          |
| Storage Temperature(°C)         |                                |
| 2nd/3rd Harmonic(dBc)           | -                              |
| Termination/Attenuator(Watt/dB) | 15W                            |
| Tab(W×LG×THK)(mm[Inch])         | 0.7[.028]×2.0[.078]×0.15[.006] |
| Additional Notes                | -                              |

**JQL** JQL Electronic Inc 500 Lake Cook Road, Suite 350 Deerfield, IL 60015, USA Tel: 1(888)236-9828 Fax: 1(888)823-2902

|                                             |                                   |                                             |                |
|---------------------------------------------|-----------------------------------|---------------------------------------------|----------------|
| <b>MATERIAL:</b><br>STEEL                   | <b>DWG NO:</b><br>JID4000T5000VM0 |                                             |                |
| <b>SURFACE TREATMENT:</b><br>NICKEL PLATING | DWG BY:                           | LJ.Zhang                                    | 03.25.2014     |
|                                             | CHK'D BY:                         |                                             | SACLE          |
| <b>DESCRIPTION:</b><br>DROP-IN ISOLATOR     | APPV'D BY:                        |                                             | 3:1            |
|                                             | Unit:<br>mm[inch]                 | Tolerance:<br>Liner: ±0.25<br>Anguar: ±0.5° | The First:<br> |
|                                             |                                   |                                             | A4             |



This document is the property of JQL Electronic Inc. It cannot be copied, duplicated, used for manufacturing purposes or communicated to third party as a whole or partly, without the written consent of JQL Electronic Inc.