

1 Stock Number

REV.	DESCRIPTION	REVISOR	DATE	APPROVE
0		MH	02.22.11	CH

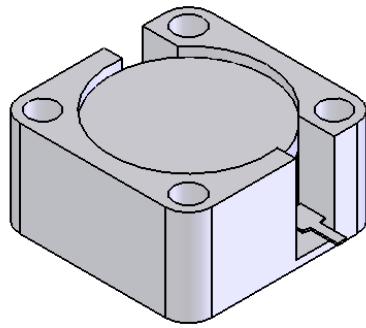
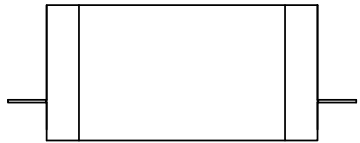

**SPECIFICATION**

Part's Number: JID6000T8000VM1  
 Frequency: 6.000~8.000GHz  
 Direction: CW  
 Insertion Loss: 0.6dB MAX.  
 Isolation: 17dB MIN.  
 RL: 17dB MIN.  
 Power : 1W  
 Temperature: -30°C~+70°C

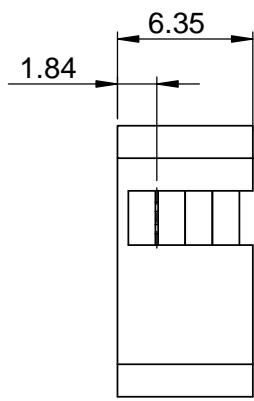
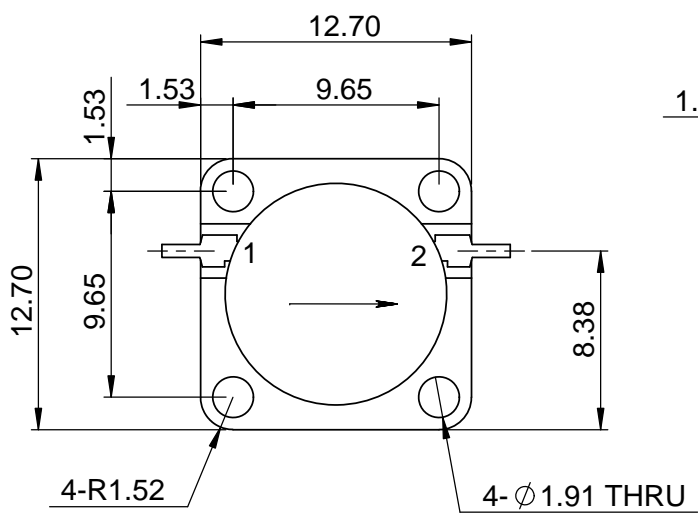

This document is the property of JQL Electronic Inc. It cannot be copied, duplicated, used for manufacturing purposes or communicated to third party as a whole or partly, without the written consent of JQL Electronic Inc.

<b>JQL</b> JQL Electronic Inc		500 Lake Cook Road, Suite 350 Deerfield, IL 60015, USA		Tel : 1(888)236-9828 Fax: 1(630)823-2902	
MATERIAL:	STEEL	DWG NO. JID6000T8000VM1			
SURFACE TREATMENT:	NICKLE PLATING	SCALE: 1:1			
DESCRIPTION:	DROP-IN ISOLATOR	DWG BY:	NAME: MH	DATE: 02.22.11	SCALE: 1:1
		CHK'D BY:	FW	02.22.11	
		APPV'D BY:	CH	02.22.11	
Unit: mm	TOLERANCE: Liner: ±0.1mm Angular: ±0.5°	Type Of Projection		A4	

WEIGHT:

SHEET 1 OF 1