

1		2		3		4		5		6	
Document No.	QR4-700-T-003	REV.	A/0	REV.	DESCRIPTION	REVISOR	DATE	APPROVED			
		0		LJ.Zhang	07.22.2015	David					

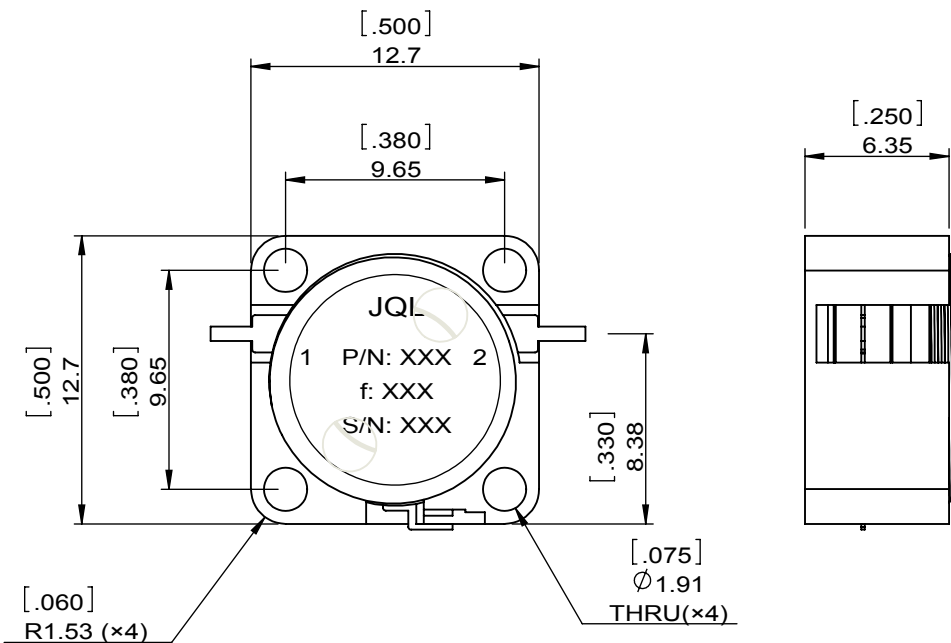

SPECIFICATIONS	
Part's Number	JID7100T8600VM0
Frequency(GHz)	7.100~8.600
Direction	CW
Insertion Loss(dB)MAX	0.40
Isolation(dB)MIN	20
Return Loss(dB)MIN	19.0
3rd IMD(dBc)MAX	-
Power FWD/REV/PK(Watt)	5/1/-
Operating Temperature(°C)	-30~+75
Storage Temperature(°C)	-
2nd/3rd Harmonic(dBc)	-
Termination/Attenuator(Watt/dB)	15/-
Tab(W×LG×THK)(mm[Inch])	.635[.03]×2.0[.078]×.13[.005]
Additional Notes	-

<b>JQL</b> JQL Electronic Inc				
<b>MATERIAL:</b> STEEL		<b>DWG NO:</b> JID7100T8600VM0		
<b>SURFACE TREATMENT:</b> NICKEL PLATING		DWG BY:	LJ.Zhang	07.22.2015
<b>DESCRIPTION:</b> DROP-IN ISOLATOR		CHK'D BY:		SCALE
		APPV'D BY:		3:1
Unit: mm[inch]	Tolerance: Liner: ±0.25 Anguar: ±0.5°	The First:		A4

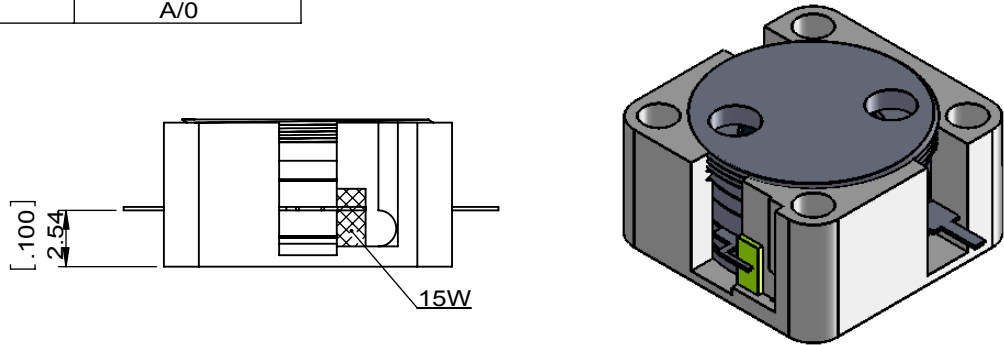

This document is the property of JQL Electronic Inc. It cannot be copied, duplicated, used for manufacturing purposes or communicated to third party as a whole or partly, without the written consent of JQL Electronic Inc.