

1		2		3		4		5		6	
Document No.	QR4-700-T-003	REV.	A/0	REV.	DESCRIPTION	REVISOR	DATE	APPROVED			
		0		JP.Yang	08.26.2013	David					

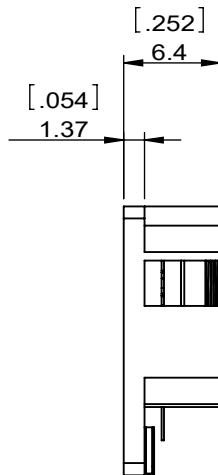
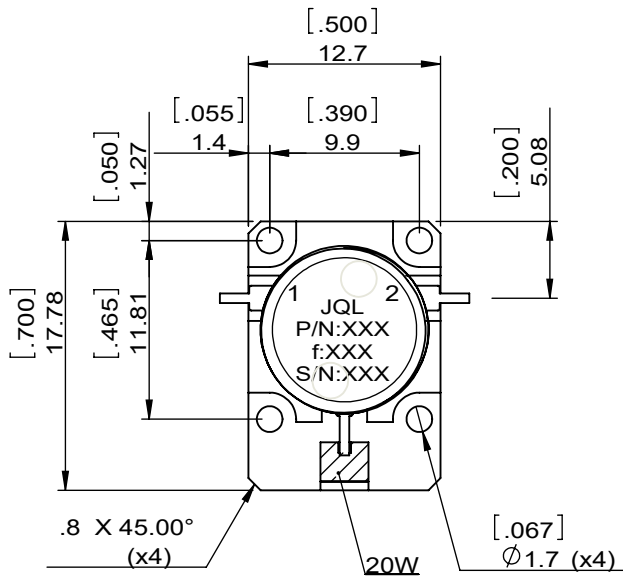
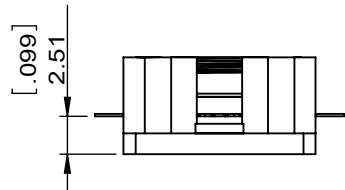
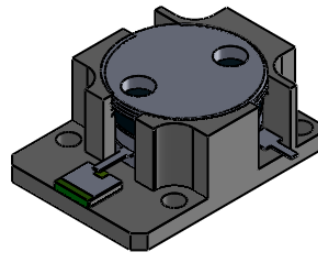

SPECIFICATIONS	
Part's Number	JID7125T7875VM1
Frequency(GHz)	7.125~7.875
Direction	CW
Insertion Loss(dB)MAX	0.50
Isolation(dB)MIN	20.0
Return Loss(dB)MIN	19.0
3rd IMD(dBc)MAX	-
Power FWD/REV/PK(Watt)	15/10/-
Operating Temperature(°C)	-40~+85
Storage Temperature(°C)	-
2nd/3rd Harmonic(dBc)	-
Termination/Attenuator(Watt/dB)	20
Tab(W×LG×THK)(mm[Inch])	0.635[.030]X1.9[.070]X0.15[.010]
Additional Notes	-

JQL	JQL Electronic Inc	500 Lake Cook Road, Suite 350	Tel: 1(888)236-9828
		Deerfield, IL 60015, USA	Fax: 1(888)823-2902

MATERIAL: STEEL	DWG NO: JID7125T7875VM1			
SURFACE TREATMENT: NICKEL PLATING	DWG BY:	JP.Yang	08.26.2013	SACLE
DESCRIPTION: DROP-IN ISOLATOR	CHK'D BY:			2:1
	APPV'D BY:			
	Unit: mm[inch]	Tolerance: Liner: ±0.25 Anguar: ±0.5°	The First:	



This document is the property of JQL Electronic Inc. It cannot be copied, duplicated, used for manufacturing purposes or communicated to third party as a whole or partly, without the written consent of JQL Electronic Inc.