

1		2		3		4		5		6	
Document No.	QR4-700-T-003	REV.	A/0	REV.	DESCRIPTION	REVISOR	DATE	APPROVED			
				0		JP.Yang	07.24.2013	David			

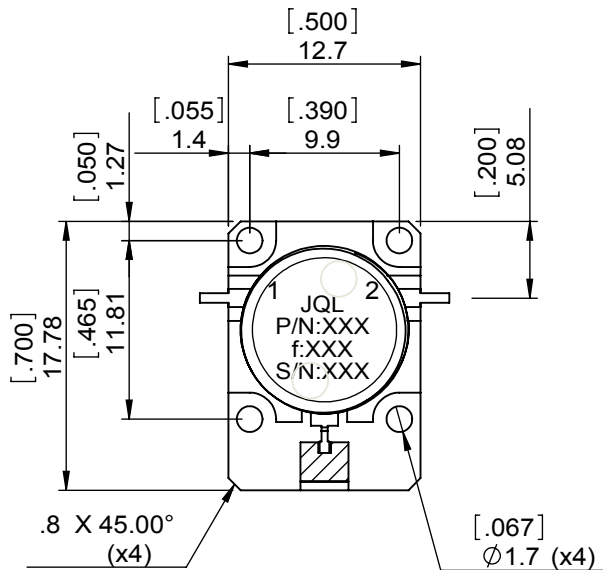
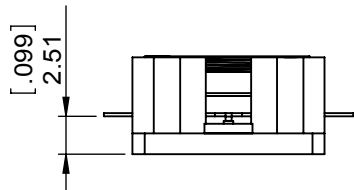
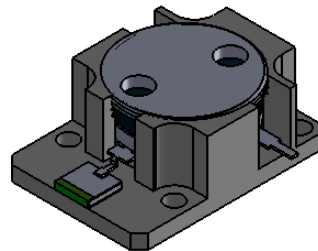

SPECIFICATIONS	
Part's Number	JID8600T9600VM2
Frequency(GHz)	8.600~9.600
Direction	CW
Insertion Loss(dB)MAX	0.40
Isolation(dB)MIN	20.0
Return Loss(dB)MIN	20.0
3rd IMD(dBc)MAX	-
Power FWD/REV/PK(Watt)	20/20/40(50% Duty Cycle)
Operating Temperature(°C)	-40~+85
Storage Temperature(°C)	-
2nd/3rd Harmonic(dBc)	-
Termination/Attenuator(Watt/dB)	-
Tab(W×LG×THK)(mm[Inch])	0.635[.030]X1.9[.070]X0.15[.010]
Additional Notes	-

**JQL** **JQL Electronic Inc** 500 Lake Cook Road, Suite 350 Deerfield, IL 60015, USA Tel: 1(888)236-9828 Fax: 1(888)823-2902

<b>MATERIAL:</b> STEEL	<b>DWG NO:</b> JID8600T9600VM2		
<b>SURFACE TREATMENT:</b> NICKEL PLATING	DWG BY:	JP.Yang	07.24.2013
	CHK'D BY:		
<b>DESCRIPTION:</b> DROP-IN ISOLATOR	APPV'D BY:		2:1
	Unit: mm[inch]	Tolerance: Liner: ±0.25 Anguar: ±0.5°	The First: 
			A4



This document is the property of JQL Electronic Inc. It cannot be copied, duplicated, used for manufacturing purposes or communicated to third party as a whole or partly, without the written consent of JQL Electronic Inc.