

1		2		3		4		5		6	
Document No.	QR4-700-T-003	REV.	A/0	REV.	DESCRIPTION	REVISOR	DATE	APPROVED			
		0		ZC.Wu	05.14.2014	David					

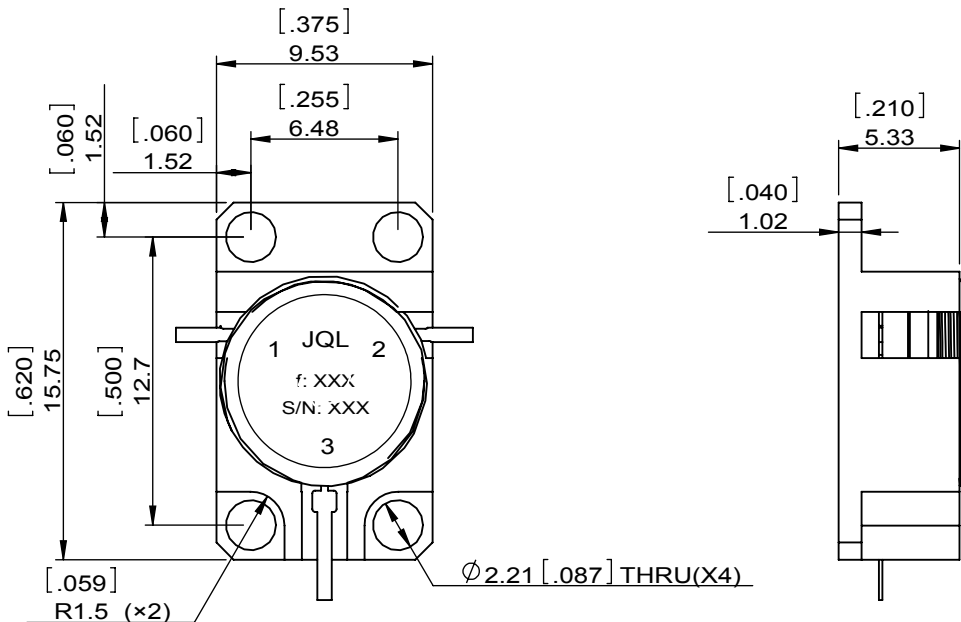

SPECIFICATIONS	
Part's Number	PACKAGE CM 0.375"X0.480"
Frequency(GHz)	12.00~18.00
Bandwidth Up to 30%	
Direction	CW
Insertion Loss(dB)MAX	0.50
Isolation(dB)MIN	20.0
Return Loss(dB)MIN	20.0
3rd IMD(dBc)MAX	-
Power FWD/REV/PK(Watt)	5/5/-
Operating Temperature(°C)	-30~+70
Storage Temperature(°C)	-
2nd/3rd Harmonic(dBc)	-
Termination/Attenuator(Watt/dB)	-
Tab(W×LG×THK)(mm[Inch])	0.64[.025]×1.78[.07]×0.13[.005]
Additional Notes	-

<b>JQL</b> JQL Electronic Inc				
<b>MATERIAL:</b> STEEL		<b>DWG NO:</b> PACKAGE CM 0.375"X0.480"		
<b>SURFACE TREATMENT:</b> SLIVER PLATING		DWG BY:	ZC.Wu	05.14.2014
<b>DESCRIPTION:</b> DROP-IN CIRCULATOR		CHK'D BY:		SACLE
		APPV'D BY:		3:1
		Unit: mm[inch]	Tolerance: Liner: ±0.25 Anguar: ±0.5°	The First: 
				A4

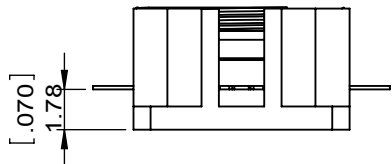
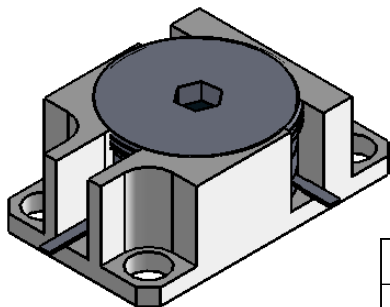

This document is the property of JQL Electronic Inc. It cannot be copied, duplicated, used for manufacturing purposes or communicated to third party as a whole or partly, without the written consent of JQL Electronic Inc.