

1		2		3		4		5		6			
Document No.	QR4-700-T-003	REV.	A/0	REV.	0	DESCRIPTION		REVISER	ZQ.Hou	DATE	10.20.2015	APPROVED	David

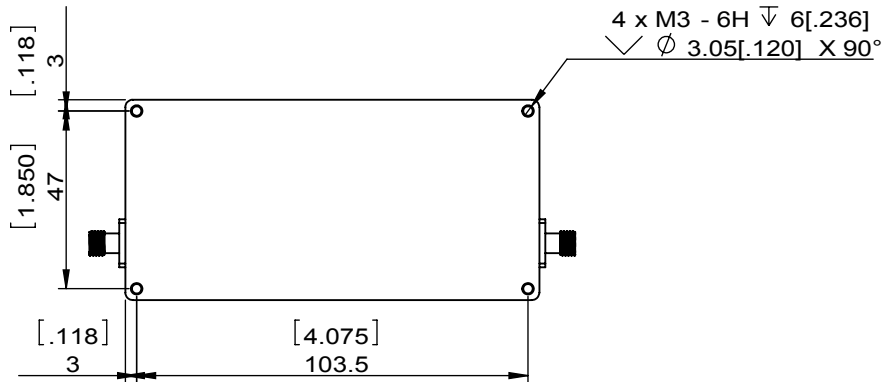

ITEM	SPECIFICATIONS
Frequency(MHz)	2700~2900
Insertion Loss(dB)	1.5 Max
Ripple(dB)	0.4 Max
Reject(dBc)	40 Min@2000~2640Mhz 40 Min@2960~5200Mhz 10 Min@5200~6000Mhz
Return Loss(dB)	14Min
Impedance(Ω)	50
Group Delay(ns)	2 within 5MHz bandwidth
Temperature(°C)	0~+85
Connector	SMA FEMALE
Notes	

JQL JQL Electronic Inc				
MATERIAL:		DWG NO:		
		JFCB2700T2900SF		
SURFACE TREATMENT:		DWG BY:	ZQ.Hou	10.20.2015
PAINTED BLACK		CHK'D BY:		SCALE
DESCRIPTION:		APPV'D BY:		1:1
FILTER		Unit:	Tolerance:	The First:
		mm[inch]	Liner: ±0.25	
			Anguar: ±0.5°	A4

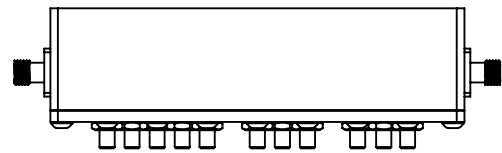
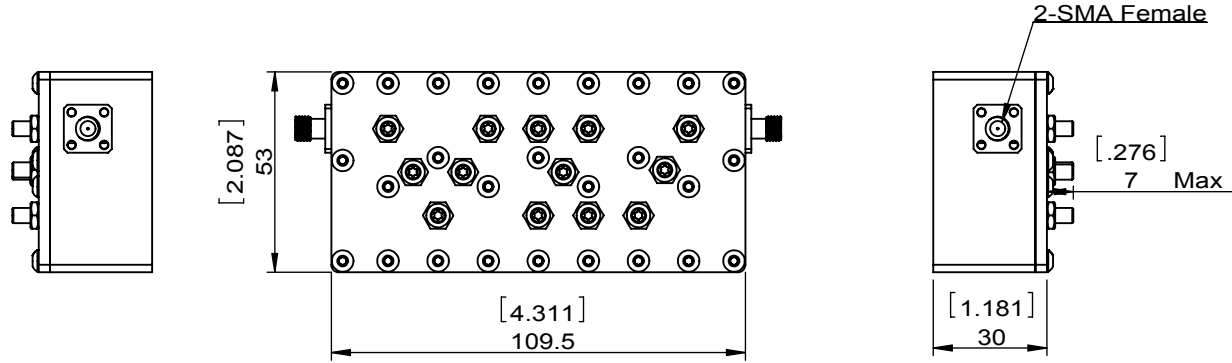

This document is the property of JQL Electronic Inc. It cannot be copied, duplicated, used for manufacturing purposes or communicated to third party as a whole or partly, without the written consent of JQL Electronic Inc.

1		2		3		4		5		6	
Document No. QR4-700-T-003								REV.		DESCRIPTION	
REV. A/0								0		ZQ.Hou	
								10.20.2015		APPROVED David	

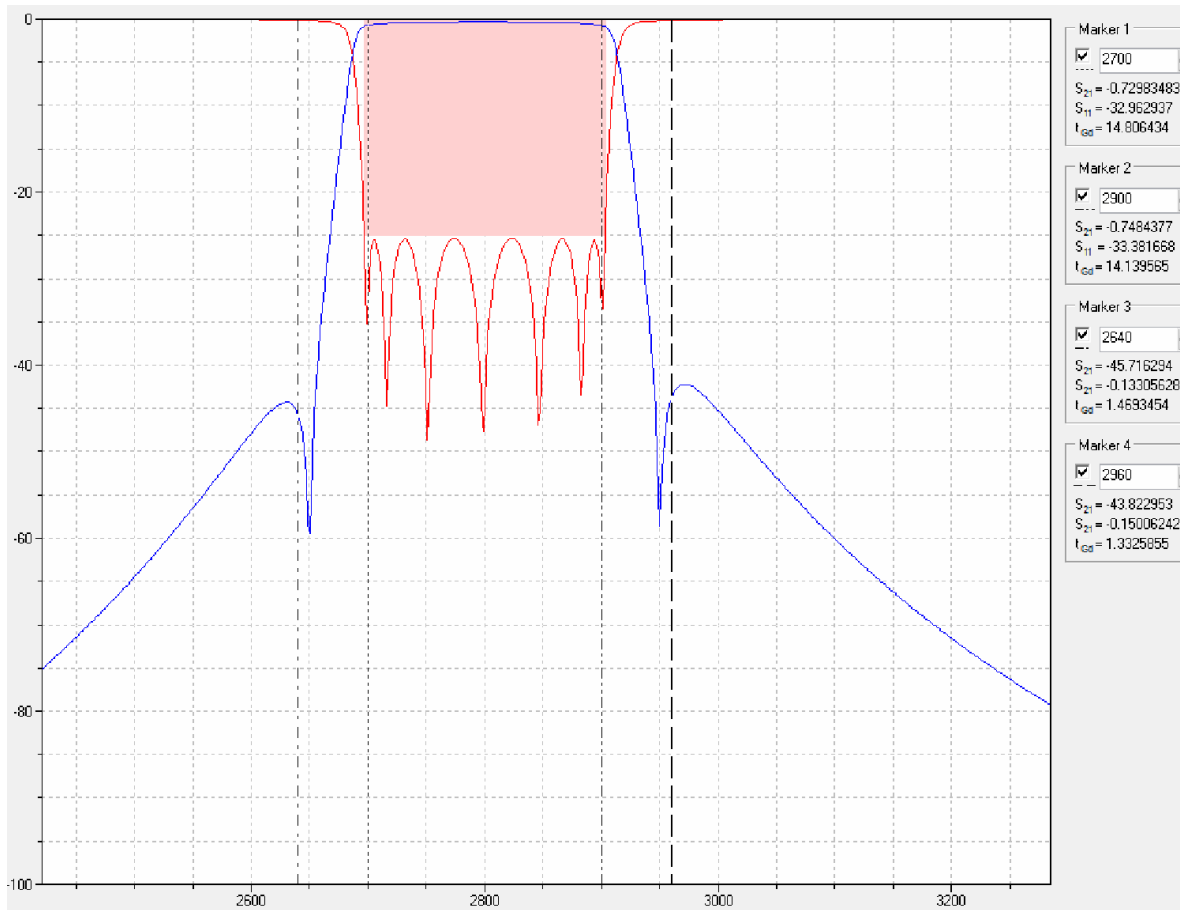

JQL JQL Electronic Inc				
MATERIAL:		DWG NO: JFCB2700T2900SF		
SURFACE TREATMENT: PAINTED BLACK		DWG BY:	ZQ.Hou	10.20.2015
DESCRIPTION: FILTER		CHK'D BY:		SCALE
		APPV'D BY:		1:1
		Unit: mm[inch]	Tolerance: Liner: ± 0.25 Anguar: $\pm 0.5^\circ$	The First:
				A4



This document is the property of JQL Electronic Inc. It cannot be copied, duplicated, used for manufacturing purposes or communicated to third party as a whole or partly, without the written consent of JQL Electronic Inc.