

1		2		3		4		5		6	
Document No.	QR4-700-T-003	REV.	A/0	REV.	DESCRIPTION	REVISOR	DATE	APPROVED			
				0		YQ.XIE	11.06.2015	David			

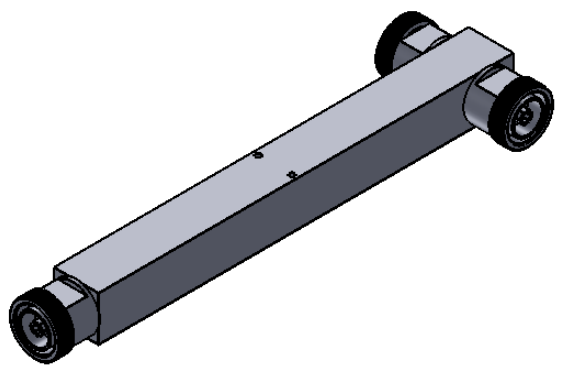

SPECIFICATIONS	
Part's Number	PSST0698T2700DF-2
Frequency(MHz)	0.698~2.700
Input	2-way
Split Loss(dB)	3.01
Insertion Loss(dB)MAX	0.2
VSWR(dB)MAX	1.3
PIM(dBc)MAX	-150dBc@2×43dBm
Power FWD/REV/PK(Watt)	500/500/2000
Impedance(Ω)	50
Connector	7/16 N-female
Color	Black
Operating Temperature(°C)	-30~+65
Application	Indoor or Outdoor,IP65
Dimensions(mm)	256.55mm×71.7mm×25mm
Additional Notes	-

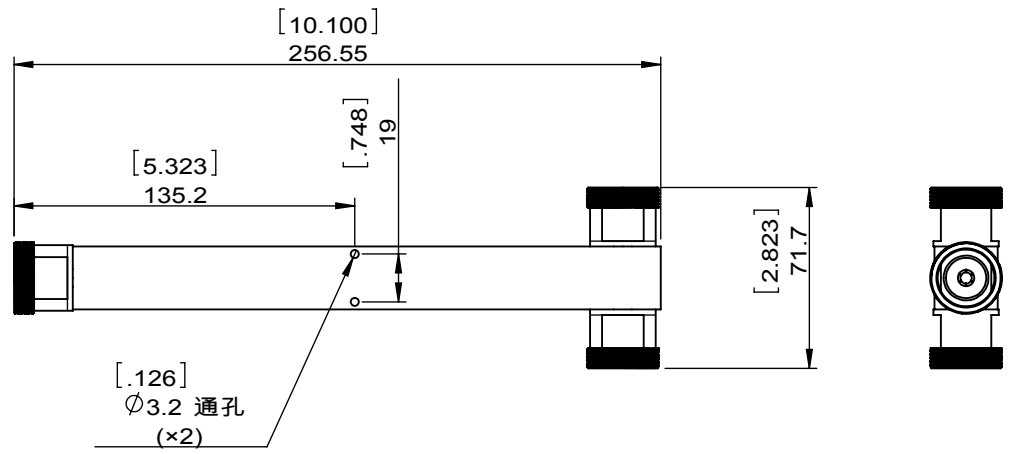

JQL JQL Electronic Inc

MATERIAL:	DWG NO: PSST0698T2700DF-2			
SURFACE TREATMENT:	DWG BY:	YQ.XIE	11.06.2015	SCALE
	CHK'D BY:			
DESCRIPTION:	APPV'D BY:			1:3
	Unit:	Tolerance:	The First:	A4
	mm[inch]	Liner: ±0.25 Anguar: ±0.5°		

RoHS COMPLIANCE
This document is the property of JQL Electronic Inc. It cannot be copied, duplicated, used for manufacturing purposes or communicated to third party as a whole or partly, without the written consent of JQL Electronic Inc.