

1		2		3		4		5		6	
Document No.	QR4-700-T-003	REV.	A/0	REV.	DESCRIPTION	REVISOR	DATE	APPROVED			
				0		ZC.Wu	03.15.2016	David			

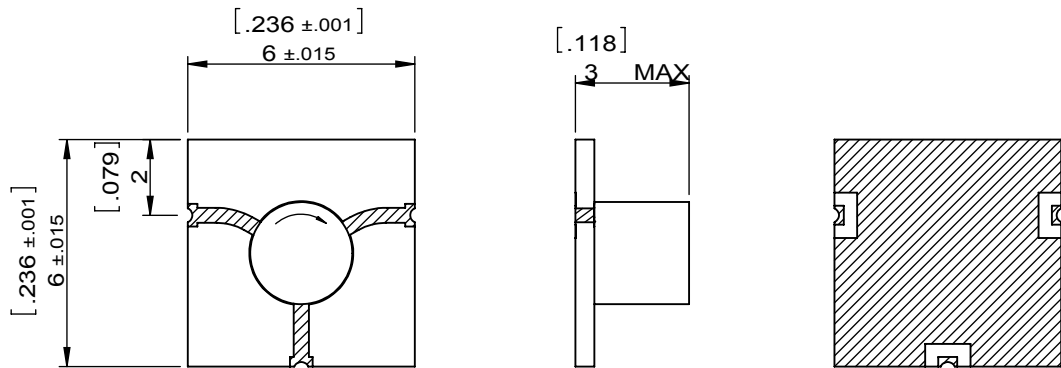

SPECIFICATIONS	
Part's Number	JCSM14K5T15K5
Frequency(GHz)	14.500~15.500
Direction	CW
Insertion Loss(dB)MAX	0.6
Isolation(dB)MIN	17.0
Return Loss(dB)MIN	17.7
3rd IMD(dBc)MAX	-
Power FWD/REV/PK(Watt)	2/2/-
Operating Temperature(°C)	-40~+85
Storage Temperature(°C)	
2nd/3rd Harmonic(dBc)	-
Termination/Attenuator(Watt/dB)	-
Tab(W×LG×THK)(mm[Inch])	-
Additional Notes	-

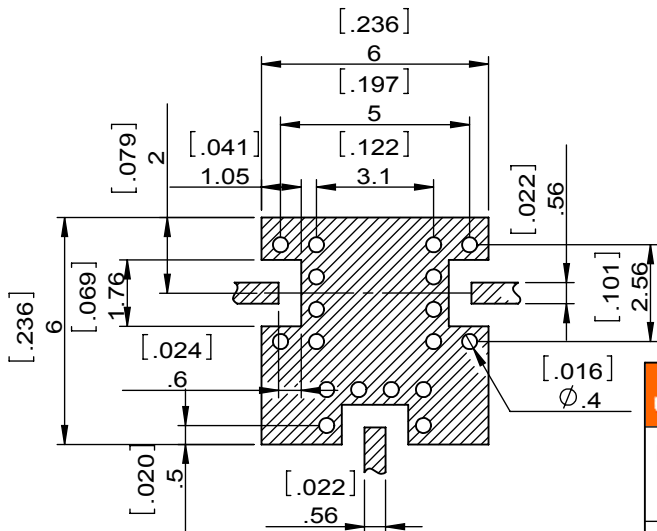

- NOTES:
- The devices should be mounted on the NON MAGNETIC carrier or base. Heat sink temperature must not exceed the maximum operate specified.
  - For Pb-free reflow profile with peak temperature 250°C @40 second.
  - Humidity 5 to 95% non-condensing.
  - Recommended configuration of land pattern on "PCB for JCSM14K5T15K5".

PCB FOR JCSM14K5T15K5  
 Material:Ro4350B  
 0.254±0.001 THICK 1/2 OZ CU CLAD



This document is the property of JQL Electronic Inc. It cannot be copied, duplicated, used for manufacturing purposes or communicated to third party as a whole or partly, without the written consent of JQL Electronic Inc.

<b>JQL JQL Electronic Inc</b>				
<b>MATERIAL:</b> Ferrite		<b>DWG NO:</b> JCSM14K5T15K5		
<b>SURFACE TREATMENT:</b> Thin Film		DWG BY:	ZC.Wu	03.15.2016
<b>DESCRIPTION:</b> Surface Mount Circulator		CHK'D BY:		SCALE
		APPV'D BY:		5:1
Unit: mm[inch]		Tolerance: Liner: ±0.25 Anguar: ±0.5°	The First:	A4