

1		2		3		4		5		6			
Document No.	QR4-700-T-003	REV.	A/0	REV.	0	DESCRIPTION		REVISOR	LJ.Zhang	DATE	06.22.2016	APPROVED	David

A

B

C

D

A

B

C

D

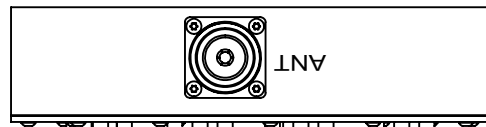
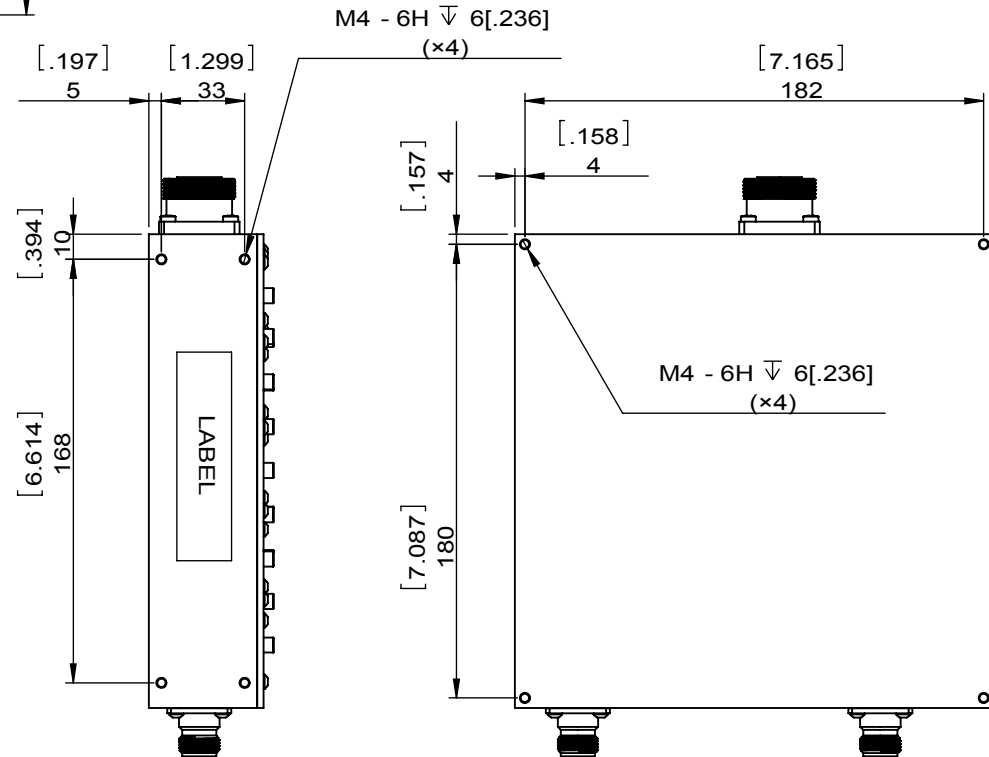
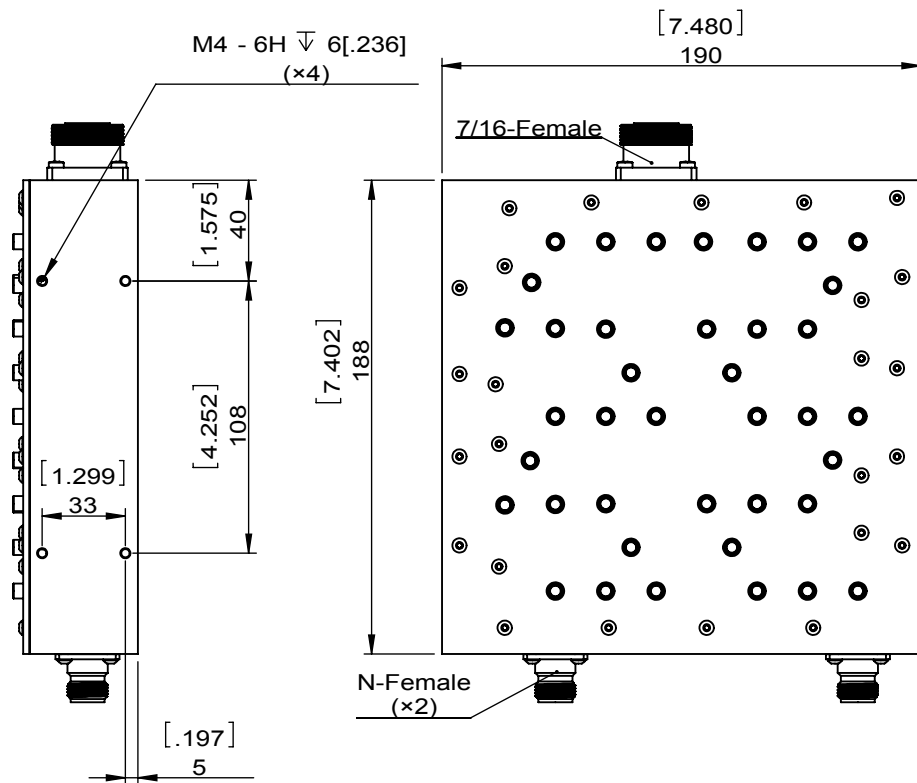
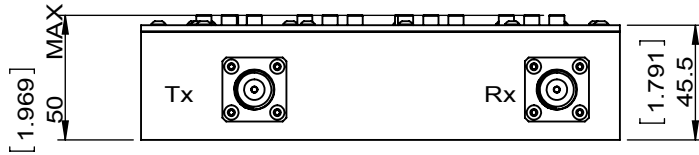

This document is the property of JQL Electronic Inc. It cannot be copied, duplicated, used for manufacturing purposes or communicated to third party as a whole or partly, without the written consent of JQL Electronic Inc.



JQL JQL Electronic Inc

MATERIAL:	DWG NO: PIM-D700B			
SURFACE TREATMENT:	DWG BY:	LJ.Zhang	06.22.2016	SCALE
DESCRIPTION:	CHK'D BY:			1:3
DUPLEXER	APPV'D BY:			
	Unit:	Tolerance:	The First:	A4
	mm[inch]	Liner: ±0.5 Anguar: ±0.5°		

WEIGHT:

5

SHEET 1 OF 3

1		2		3		4		5		6	
Document No.		QR4-700-T-003		REV.		DESCRIPTION		REVISOR		DATE	
REV.		A/0		0				LJ.Zhang		06.22.2016	
APPROVED		David									
ITEM		SPECIFICATIONS									
		Rx				Tx					
Frequency(MHz)		703~748				758~803					
Insertion Loss(dB)		1.2 Max				1.2 Max					
Isolation(dB)		95Min									
Intermodulation(dBc)		< 171 (3rd order;with 2*43dBm)									
Retrun loss(dB)		18 Min									
Ripple(dB)		1.2Max				1.2Max					
Operation Temperature(°C)		-10~+70									
Storage Tmeperature(°C)		-40~+85									
Connector		7/16-Female :ANT N-Female: Rx Tx									
 <p>This document is the property of JQL Electronic Inc. It cannot be copied, duplicated, used for manufacturing purposes or communicated to third party as a whole or partly, without the written consent of JQL Electronic Inc.</p>		 JQL Electronic Inc		MATERIAL:		DWG NO: PIM-D700B					
		SURFACE TREATMENT:		DWG BY: LJ.Zhang		06.22.2016		SCALE			
		DESCRIPTION: DUPLEXER		APPV'D BY:		1:2.5					
		Unit: mm[inch]		Tolerance: Liner: ±0.5 Anguar: ±0.5°		The First:					
								A4			
1		2		3		WEIGHT:		5		SHEET 2 OF 3	

1		2		3		4		5		6	
Document No. QR4-700-T-003						REV. 0		DESCRIPTION		REVISOR LJ.Zhang	
REV. A/0										DATE 06.22.2016	
										APPROVED David	

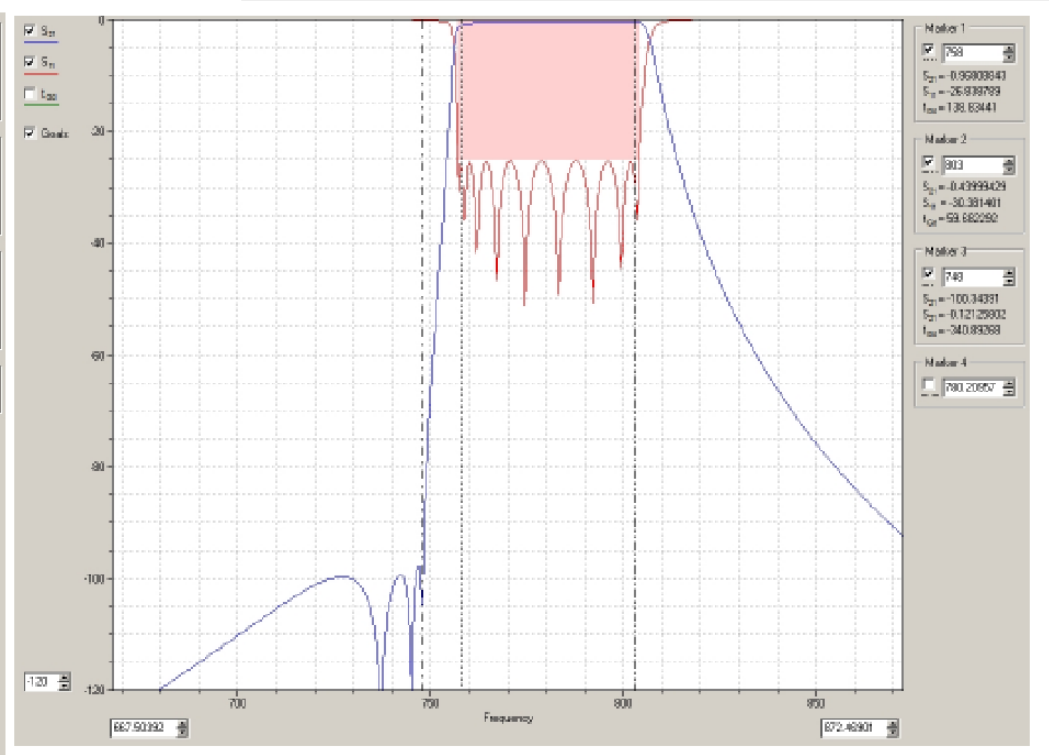
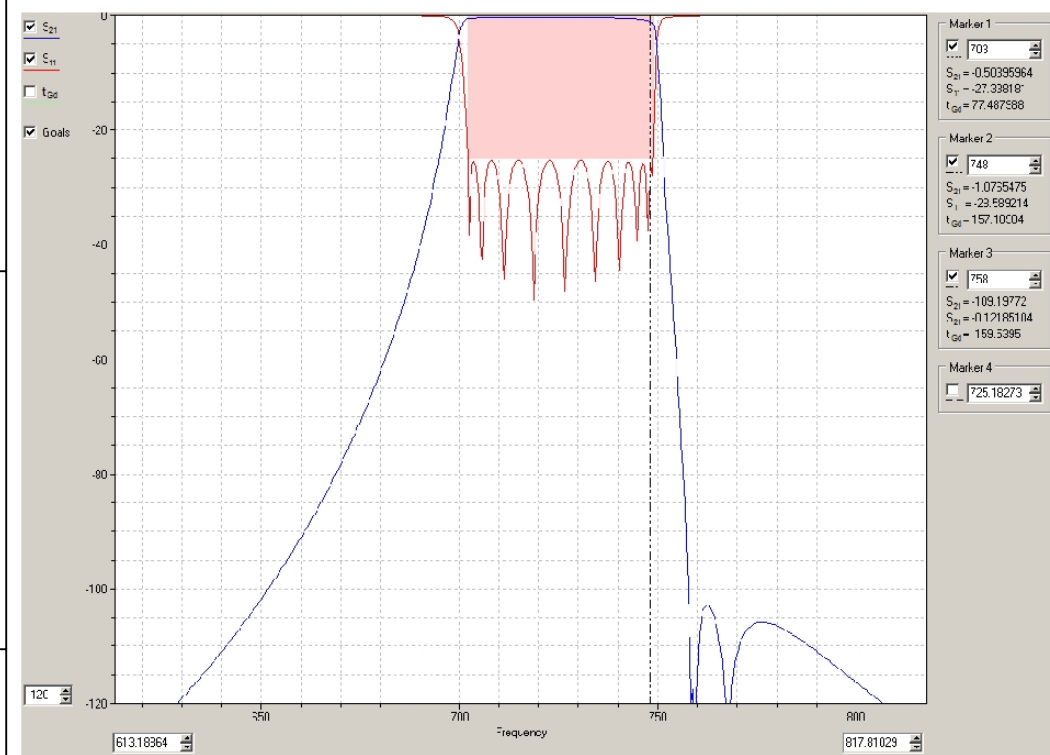

JQL JQL Electronic Inc				
MATERIAL:		DWG NO: PIM-D700B		
SURFACE TREATMENT:		DWG BY: LJ.Zhang	06.22.2016	SCALE
DESCRIPTION: DUPLEXER		CHK'D BY:		1:2.5
		APPV'D BY:		
		Unit: mm[inch]	Tolerance: Liner: ± 0.5 Anguar: $\pm 0.5^\circ$	The First:
				A4



This document is the property of JQL Electronic Inc. It cannot be copied, duplicated, used for manufacturing purposes or communicated to third party as a whole or partly, without the written consent of JQL Electronic Inc.