

1		2		3		4		5		6	
Document No.	QR4-700-T-003	REV.	A/0	REV.	DESCRIPTION	REVISOR	DATE	APPROVED			
				0		ZC.Wu	11.02.2016	David			

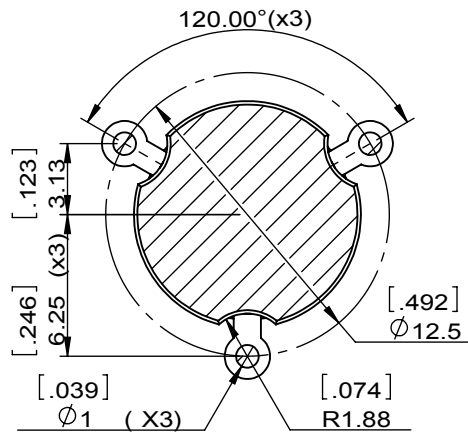

SPECIFICATIONS	
Part's Number	JCM1805T1880PT1
Frequency(GHz)	1.805~1.880
Direction	CW
Insertion Loss(dB)MAX	0.25
Isolation(dB)MIN	20.0
Return Loss(dB)MIN	20.0
3rd IMD(dBc)MAX	-65@2X10W
Power FWD/REV/PK(Watt)	10/10/-
Operating Temperature(°C)	-40~+125
Storage Temperature(°C)	
2nd/3rd Harmonic(dBc)	
Termination/Attenuator(Watt/dB)	
Tab(W×LG×THK)(mm[Inch])	-
Additional Notes	

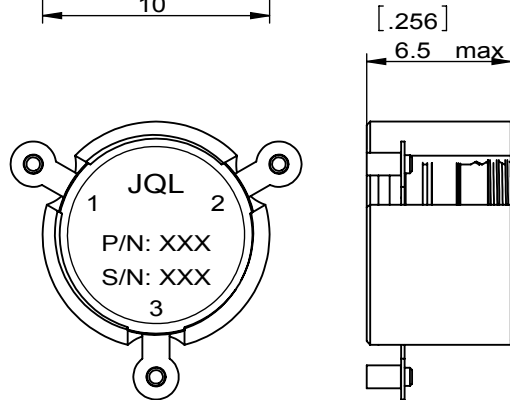
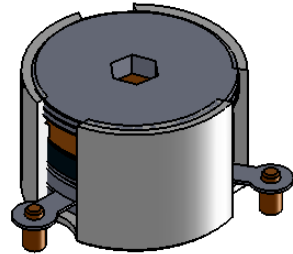
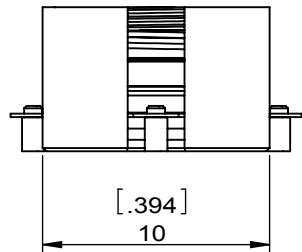
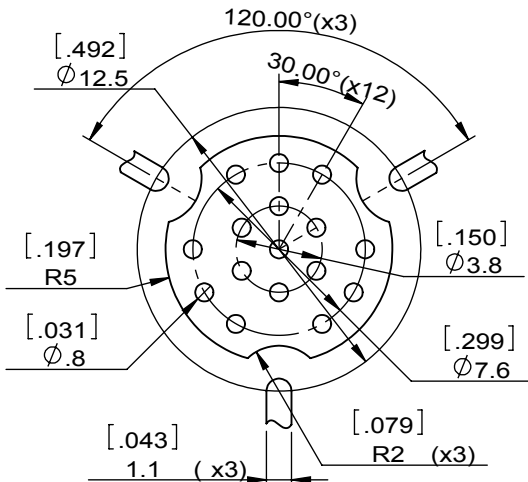

Copper Pattern

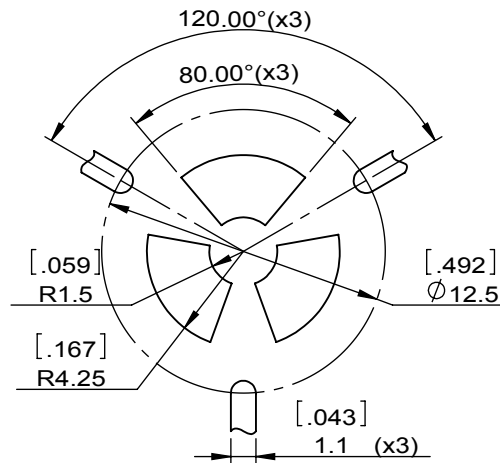

Soldermask Pattern

JQL JQL Electronic Inc				
MATERIAL: STEEL		DWG NO: JCM1805T1880PT1		
SURFACE TREATMENT: SILVER PLATING		DWG BY:	ZC.Wu	11.02.2016
DESCRIPTION: SMT CIRCULATOR		CHK'D BY:		SCALE
		APPV'D BY:		3:1
Unit: mm[inch]		Tolerance: Liner: ±0.25	The First:	
		Anguar: ±0.5°	A4	



This document is the property of JQL Electronic Inc. It cannot be copied, duplicated, used for manufacturing purposes or communicated to third party as a whole or partly, without the written consent of JQL Electronic Inc.