

1		2		3		4		5		6	
Document No.	QR4-700-T-003	REV.	A/0	REV.	DESCRIPTION	REVISOR	DATE	APPROVED			
		0		ZC.Wu	11.24.2017	David					

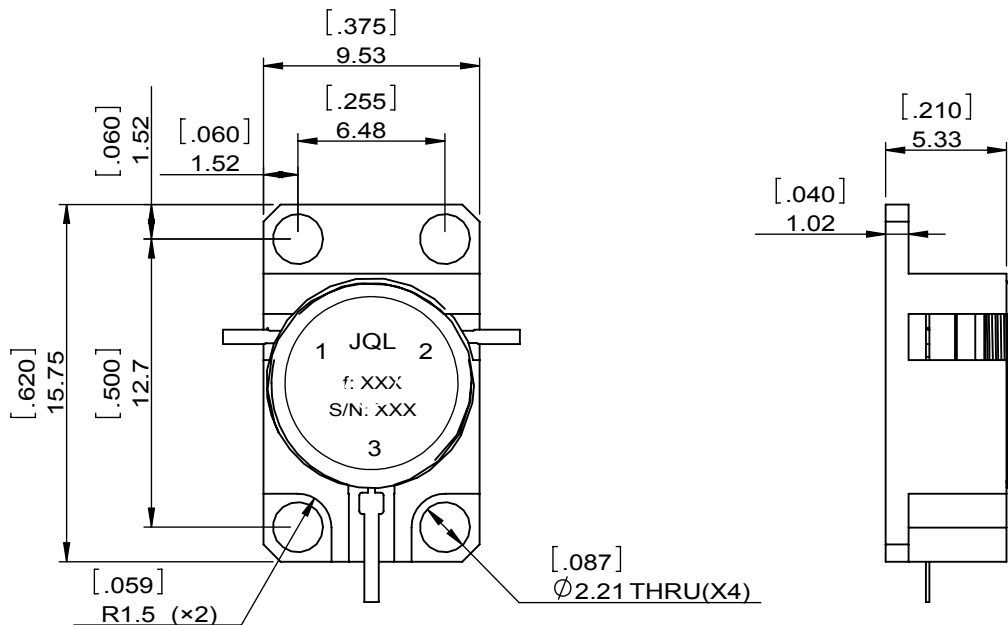

SPECIFICATIONS	
Part's Number	JCD32K5T34K5JM0
Frequency(GHz)	32.500~34.500
Direction	CW
Insertion Loss(dB)MAX	1.0
Isolation(dB)MIN	18.0
Return Loss(dB)MIN	18.0
3rd IMD(dBc)MAX	-
Power FWD/REV/PK(Watt)	5/5/-
Operating Temperature(°C)	-30~+70
Storage Temperature(°C)	-
2nd/3rd Harmonic(dBc)	-
Termination/Attenuator(Watt/dB)	-
Tab(W×LG×THK)(mm[Inch])	0.64[.025]×1.78[.07]×0.13[.005]
Additional Notes	-

JQL JQL Electronic Inc				
MATERIAL: STEEL		DWG NO: JCD32K5T34K5JM0		
SURFACE TREATMENT: SLIVER PLATING		DWG BY:	ZC.Wu	11.24.2017
DESCRIPTION: DROP-IN CIRCULATOR		CHK'D BY:		SACLE
		APPV'D BY:		3:1
		Unit: mm[inch]	Tolerance: Liner: ±0.25 Anguar: ±0.5°	The First:
				A4

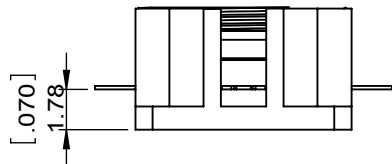
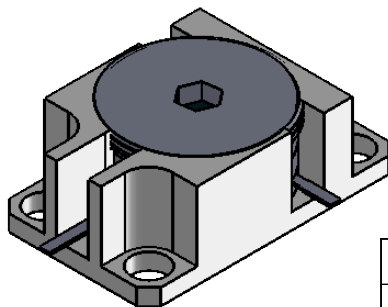

This document is the property of JQL Electronic Inc. It cannot be copied, duplicated, used for manufacturing purposes or communicated to third party as a whole or partly, without the written consent of JQL Electronic Inc.