

|              |               |      |     |      |             |         |            |          |  |   |  |
|--------------|---------------|------|-----|------|-------------|---------|------------|----------|--|---|--|
| 1            |               | 2    |     | 3    |             | 4       |            | 5        |  | 6 |  |
| Document No. | QR4-700-T-003 | REV. | A/0 | REV. | DESCRIPTION | REVISOR | DATE       | APPROVED |  |   |  |
|              |               |      |     | 0    |             | ZC.Wu   | 12.19.2017 | HC.Qiu   |  |   |  |

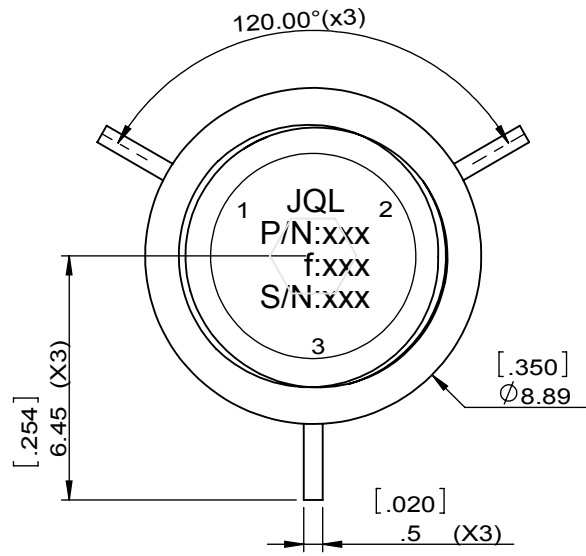
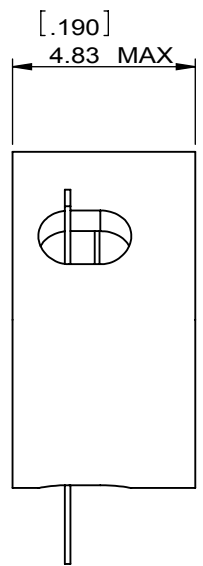
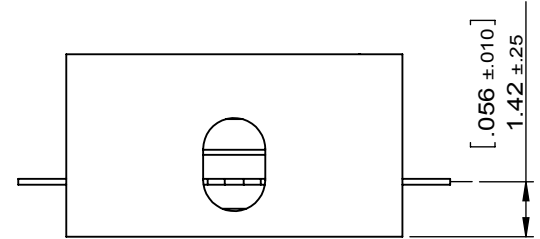
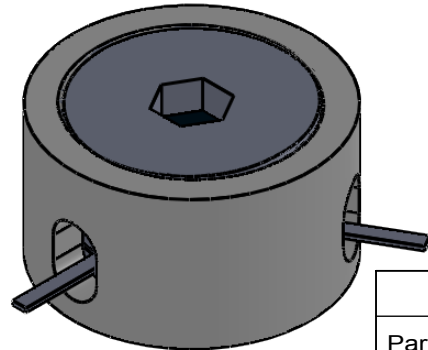

| SPECIFICATIONS                  |                 |
|---------------------------------|-----------------|
| Part's Number                   | JCM15K0T17K0ZM1 |
| Frequency(GHz)                  | 15.000~17.000   |
| Direction                       | CW              |
| Insertion Loss(dB)MAX           | 1.7             |
| Isolation(dB)MIN                | 17.0            |
| Return Loss(dB)MIN              | 17.0            |
| 3rd IMD(dBc)MAX                 | -               |
| Power FWD/REV/PK(Watt)          | 5/5/-           |
| Operating Temperature(°C)       | -40~+100        |
| Storage Temperature(°C)         | -               |
| 2nd/3rd Harmonic(dBc)           | -               |
| Termination/Attenuator(Watt/dB) | -               |
| Tab(W×LG×THK)(mm[Inch])         |                 |
| Additional Notes                | -               |

|   |  |                                   |   |                |
|---|--|-----------------------------------|---|----------------|
| <b>JQL</b> JQL Electronic Inc                               |  |                                   |   |                |
| <b>MATERIAL:</b><br>STEEL                                   |  | <b>DWG NO:</b><br>JCM15K0T17K0ZM1 |   |                |
| <b>SURFACE TREATMENT:</b><br>SILVER PLATING OR GOLD PLATING |  | DWG BY:                           | ZC.Wu                                       | 12.19.2017     |
| <b>DESCRIPTION:</b><br>SMT CIRCULATOR                       |  | CHK'D BY:                         |   | SCALE          |
|   |  | APPV'D BY:                        |   | 5:1            |
|   |  | Unit:<br>mm[inch]                 | Tolerance:<br>Liner: ±0.25<br>Anguar: ±0.5° | The First:<br> |
|   |  |                                   |   | A4             |

**RoHS COMPLIANCE**

This document is the property of JQL Electronic Inc. It cannot be copied, duplicated, used for manufacturing purposes or communicated to third party as a whole or partly, without the written consent of JQL Electronic Inc.

A  
B  
C  
D

A  
B  
C  
D