

1		2		3		4		5		6			
Document No.	QR4-700-T-003	REV.	A/0	REV.	0	DESCRIPTION		REVISOR	Hu.Jiang	DATE	08.20.2018	APPROVED	HC.Qiu

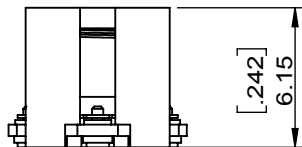

SPECIFICATIONS	
Part's Number	JCM3400T3600R0
Frequency(GHz)	3.400~3.600
Direction	CW
Insertion Loss(dB)MAX	0.3
Isolation(dB)MIN	20.0
Return Loss(dB)MIN	20.0
3rd IMD(dBc)MAX	-
Power FWD/REV/PK(Watt)	5/5/-
Operating Temperature(°C)	-40~+85
Storage Temperature(°C)	--
2nd/3rd Harmonic(dBc)	--
Termination/Attenuator(Watt/dB)	--
Tab(W×LG×THK)(mm[Inch])	-
Additional Notes	-

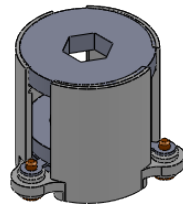
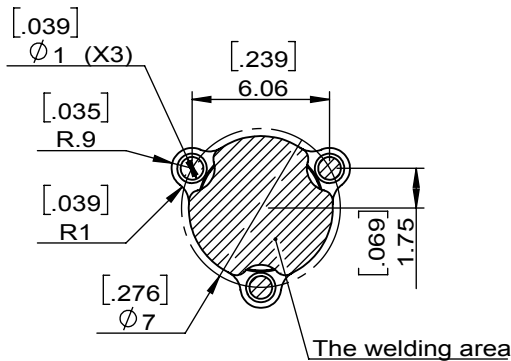
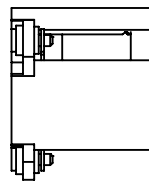
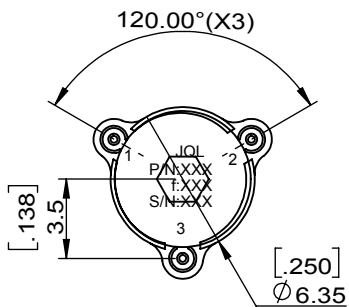

JQL JQL Electronic Inc				
MATERIAL: STEEL		DWG NO: JCM3400T3600R0		
SURFACE TREATMENT: SILVER PLATING		DWG BY:	Hu.Jiang	08.20.2018
DESCRIPTION: SMT CIRCULATOR		CHK'D BY:		SCALE
		APPV'D BY:		3:1
		Unit: mm[inch]	Tolerance: Liner: ±0.25 Anguar: ±0.5°	The First:
				A4



This document is the property of JQL Electronic Inc. It cannot be copied, duplicated, used for manufacturing purposes or communicated to third party as a whole or partly, without the written consent of JQL Electronic Inc.

WEIGHT:

SHEET 1 OF 1