

1		2		3		4		5		6	
Document No.	QR4-700-T-003	REV.	A/0	REV.	DESCRIPTION	REVISOR	DATE	APPROVED			
				0		Hu.Jiang	09.04.2018	CH.Qiu			

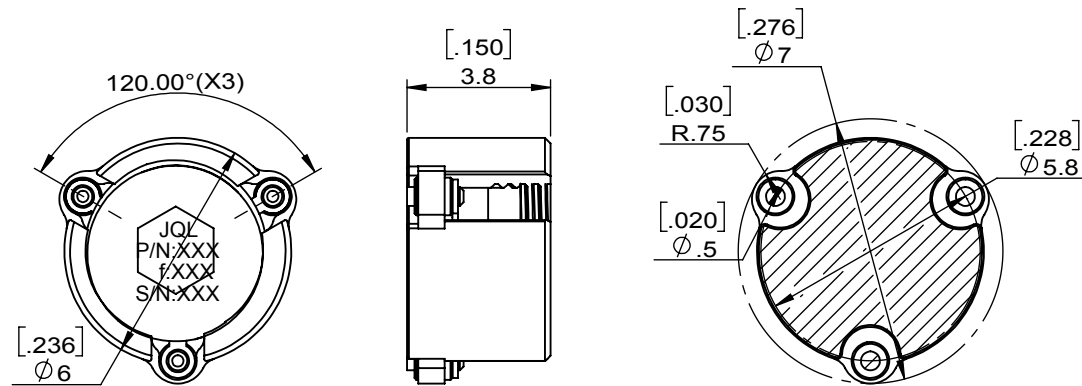

SPECIFICATIONS	
Part's Number	JCM3400T3600XM0
Frequency(GHz)	3.400~3.600
Direction	CW
Insertion Loss(dB)MAX	0.3
Isolation(dB)MIN	20.0
Return Loss(dB)MIN	20.0
3rd IMD(dBc)MAX	-
Power FWD/REV/PK(Watt)	5/5/-
Operating Temperature(°C)	-40~+85
Storage Temperature(°C)	-
2nd/3rd Harmonic(dBc)	-
Termination/Attenuator(Watt/dB)	-
Tab(W×LG×THK)(mm[Inch])	-
Additional Notes	-

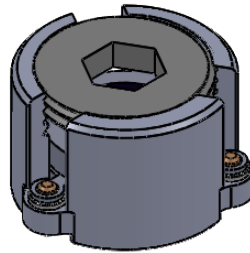
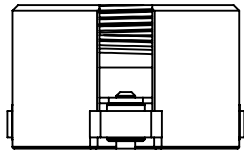
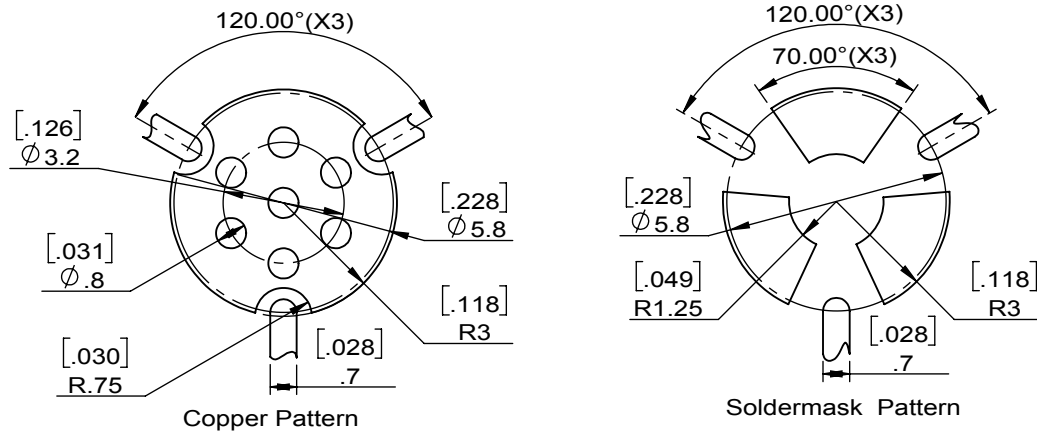

JQL JQL Electronic Inc				
MATERIAL: STELL		DWG NO: JCM3400T3600XM0		
SURFACE TREATMENT: SILVER PLATING		DWG BY:	Hu.Jiang	09.04.2018
DESCRIPTION: SMT CIRCULATOR		CHK'D BY:		SCALE
		APPV'D BY:		5:1
Unit: mm[inch]		Tolerance: Liner: ±0.25 Anguar: ±0.5°	The First:	A4



This document is the property of JQL Electronic Inc. It cannot be copied, duplicated, used for manufacturing purposes or communicated to third party as a whole or partly, without the written consent of JQL Electronic Inc.