

1		2		3		4		5		6	
Document No.	QR4-700-T-003	REV.	A/0	REV.	DESCRIPTION	REVISOR	DATE	APPROVED			
				0		Hu.Jiang	05.07.2019	HC.Qiu			

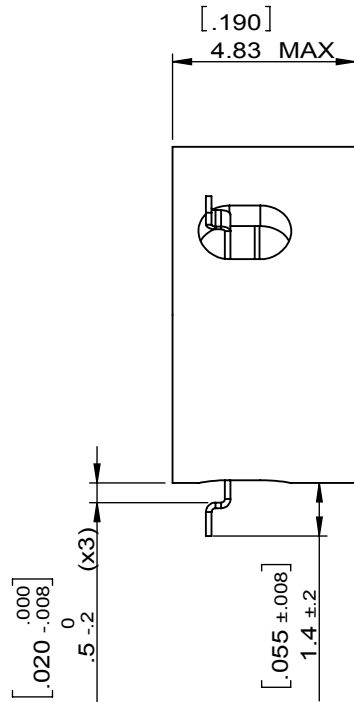

SPECIFICATIONS	
Part's Number	JCM17K3T21K5ZM0
Frequency(GHz)	17.300~21.5
Direction	CW
Insertion Loss(dB)MAX	1.0
Isolation(dB)MIN	16.0
Return Loss(dB)MIN	16.0
3rd IMD(dBc)MAX	-
Power FWD/REV/PK(Watt)	0.1/0.1/-
Operating Temperature(°C)	-40~+85
Storage Temperature(°C)	-
2nd/3rd Harmonic(dBc)	-
Termination/Attenuator(Watt/dB)	-
Reflection Phase(P2)	
Additional Notes	FILL ALL RTV AT 3 PORTS

MATERIAL: STEEL		DWG NO: JCM17K3T21K5ZM0		
SURFACE TREATMENT: GOLD PLATING		DWG BY:	Hu.Jiang	05.07.2019
DESCRIPTION: SMT CIRCULATOR		CHK'D BY:		SCALE
		APPV'D BY:		5:1
Unit:	Tolerance:	The First:		
mm[inch]	Liner: ±0.1 Anguar: ±0.5°			

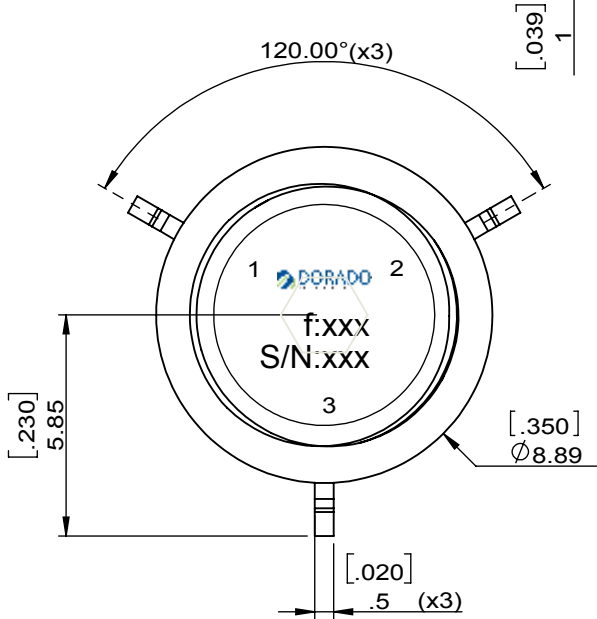
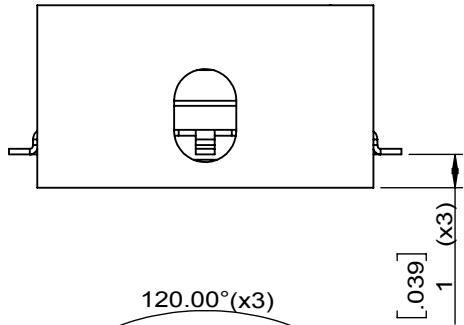
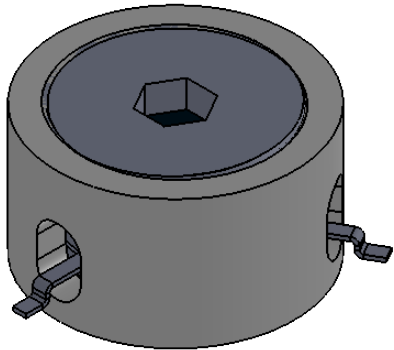

This document is the property of DORADO Millimeter Corp
It cannot be copied, duplicated, used for manufacturing purposes
or communicated to third party as a whole or partly,
without the written consent of DORADO Millimeter Corp.