

1	2
Document No.	QR4-700-T-003
REV.	A/0

4	5	6		
REV.	DESCRIPTION	REVISOR	DATE	APPROVED
0		Hu.Jiang	05.03.2018	HC.Qiu
1	Size Update	Hu.Jiang	05.15.2018	HC.Qiu
2	Update Phase	Hu.Jiang	09.04.2018	HC.Qiu

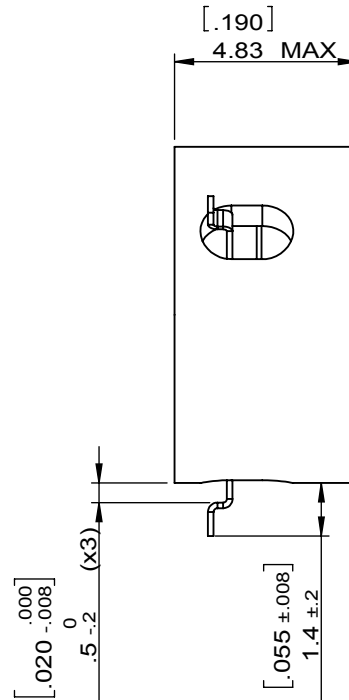
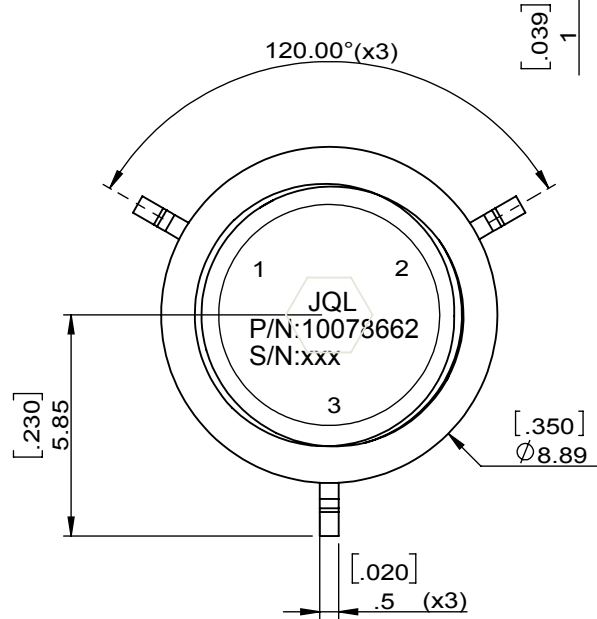
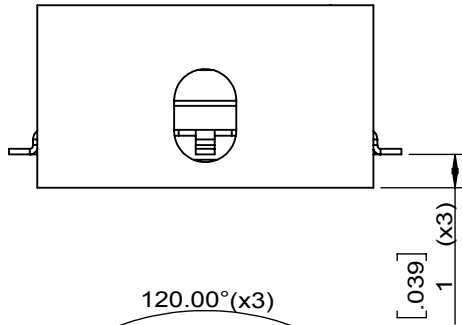
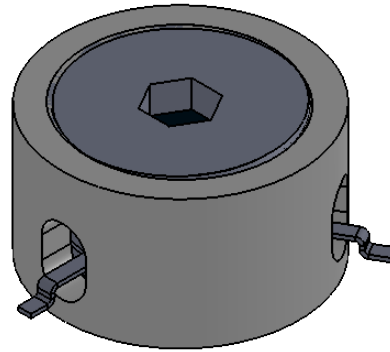

SPECIFICATIONS	
Part's Number	JCM15K0T18K0ZM1
Frequency(GHz)	15.000~18.000
Direction	CW
Insertion Loss(dB)MAX	0.7@15.5~17.5GHz 1.0@15.0~18.0GHz
Isolation(dB)MIN	16.0@15.5~17.5GHz 12.0@15.0~18.0GHz
Return Loss(dB)MIN	P1&P3:16.0@15.5~17.5GHz 10.0@15.0~18.0GHz P2 :20.0@15.5~17.5GHz 10.0@15.0~18.0GHz
3rd IMD(dBc)MAX	-
Power FWD/REV/PK(Watt)	1/1/-
Operating Temperature(°C)	-40~+100
Storage Temperature(°C)	-
2nd/3rd Harmonic(dBc)	-
Termination/Attenuator(Watt/dB)	-
Reflection Phase(P2)	-90°~0° nom at 16.5GHz
Additional Notes	FILL ALL RTV AT 3 PORTS

JQL JQL Electronic Inc				
MATERIAL: STEEL		DWG NO: JCM15K0T18K0ZM1		
SURFACE TREATMENT: GOLD PLATING		DWG BY:	Hu.Jiang	05.03.2018
DESCRIPTION: SMT CIRCULATOR		CHK'D BY:		SCALE
		APPV'D BY:		5:1
		Unit: mm[inch]	Tolerance: Liner: ±0.1 Anguar: ±0.5°	The First:
				A4



This document is the property of JQL Electronic Inc. It cannot be copied, duplicated, used for manufacturing purposes or communicated to third party as a whole or partly, without the written consent of JQL Electronic Inc.

Document No.	QR4-700-T-003
REV.	A/0

REV.	DESCRIPTION	REVISOR	DATE	APPROVED
0		Hu.Jiang	05.03.2018	HC.Qiu
1	Size Update	Hu.Jiang	05.15.2018	HC.Qiu
2	Update Phase	Hu.Jiang	09.04.2018	HC.Qiu

CH4 PHA 30 ° / REF 0 °
 S22 5: -39.602 ° 16.500 000 000 GHz

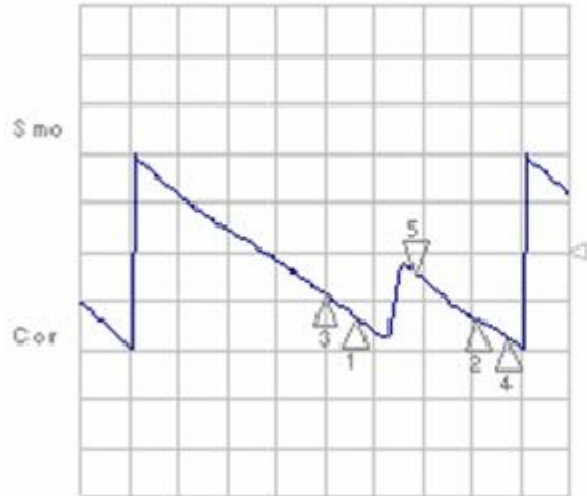

CH4 Markers

- 1: -119.50 °
15.5000 GHz
- 2: -125.85 °
17.5000 GHz
- 3: -77.756 °
15.0000 GHz
- 4: -157.39 °
16.0000 GHz

START 11000.000 MHz STOP 13000.000 MHz

JQL JQL Electronic Inc

MATERIAL: STEEL	DWG NO: JCM15K0T18K0ZM1-SAB			
SURFACE TREATMENT: GOLD PLATING	DWG BY:	Hu.Jiang	05.03.2018	SCALE
	CHK'D BY:			
DESCRIPTION: SMT CIRCULATOR	APPV'D BY:			5:1
	Unit:	Tolerance:	The First:	A4
	mm[inch]	Liner: ±0.1 Anguar: ±0.5°		



This document is the property of JQL Electronic Inc. It cannot be copied, duplicated, used for manufacturing purposes or communicated to third party as a whole or partly, without the written consent of JQL Electronic Inc.