

1	2
Document No.	QR4-700-T-003
REV.	A/0

4	5	6		
REV.	DESCRIPTION	REVISOR	DATE	APPROVED
0		Hu.Jiang	11.01.2019	HC.Qiu

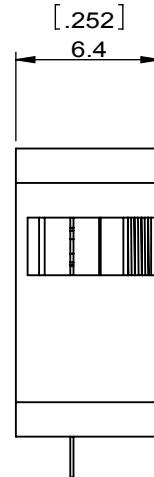
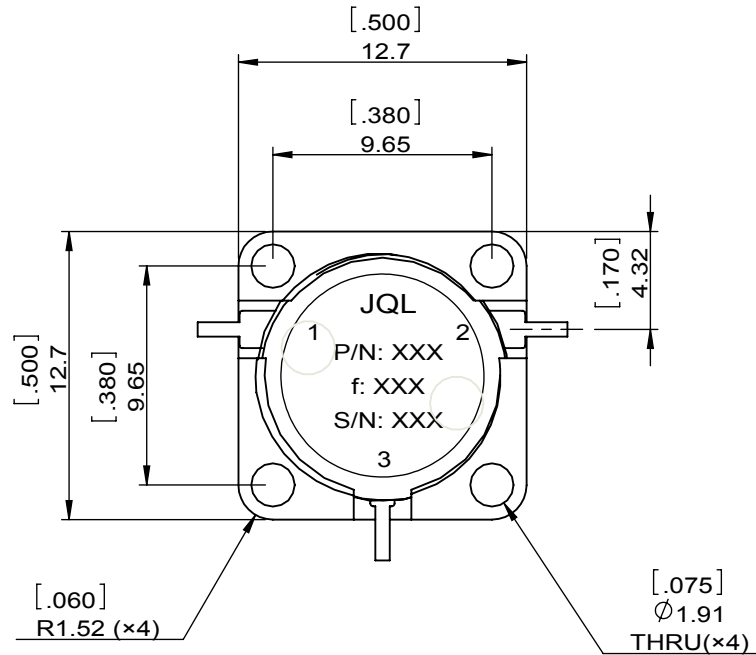
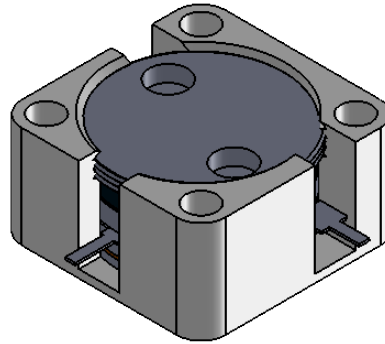
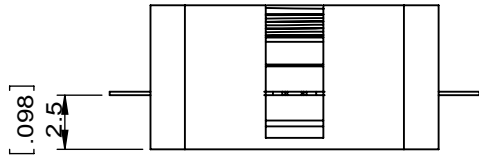

SPECIFICATIONS	
Part's Number	JCD8996T10K0VM8
Frequency(GHz)	8.996~10.000
Direction	CW
Insertion Loss(dB)MAX	0.4
Isolation(dB)MIN	20.0
Return Loss(dB)MIN	20.0
3rd IMD(dBc)MAX	-
Power FWD/REV/PK(Watt)	-/-/80 pulse 40us, duty 20%
Operating Temperature(°C)	-30~+85
Storage Temperature(°C)	-
2nd/3rd Harmonic(dBc)	-
Termination/Attenuator(Watt/dB)	-
Tab(W×LG×THK)(mm[Inch])	0.70[.03]×1.8[.070]×.20[.008]
Additional Notes	-

JQL JQL Electronic Inc				
MATERIAL: STEEL		DWG NO: JCD8996T10K0VM8		
SURFACE TREATMENT: NICKEL PLATING		DWG BY:	Hu.Jiang	11.01.2019
DESCRIPTION: DROP-IN CIRCULATOR		CHK'D BY:		SCALE
		APPV'D BY:		3:1
		Unit: mm[inch]	Tolerance: Liner: ±0.25 Anguar: ±0.5°	The First:
				A4



This document is the property of JQL Electronic Inc. It cannot be copied, duplicated, used for manufacturing purposes or communicated to third party as a whole or partly, without the written consent of JQL Electronic Inc.