

1		2		3		4		5		6	
Document No.	QR4-700-T-003					REV.	DESCRIPTION	REVISOR	DATE	APPROVED	
REV.	A/0					0		YL.Chen	11.25.2019	HC.Qiu	

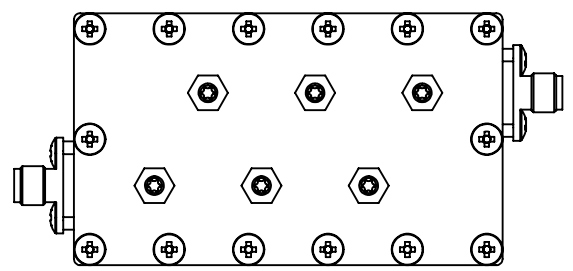

ITEM	SPECIFICATIONS
Frequency(MHz)	7900~8400
Insertion Loss(dB)	0.5 Max
Return Loss(dB)	16 Min
Rejection(dB)	50 Min @ 7250 ~ 7750MHz
Power(W)	20 CW
Operating Temperature(°C)	-30~+100
Connector	SMA-Female
Additional Notes	-

JQL JQL Electronic Inc				
MATERIAL:		DWG NO:		
		JFCB7900T8400SF-B		
SURFACE TREATMENT:		DWG BY:	YL.Chen	11.25.2019
Silver Plating		CHK'D BY:		SCALE
DESCRIPTION:		APPV'D BY:		1:1
Filter		Unit:	Tolerance:	The First:
		mm[inch]	Liner: ±0.25	
			Anguar: ±0.5°	A4

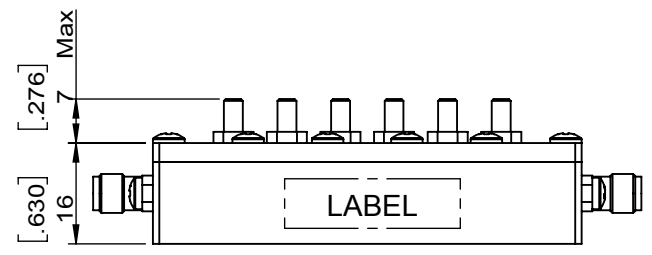
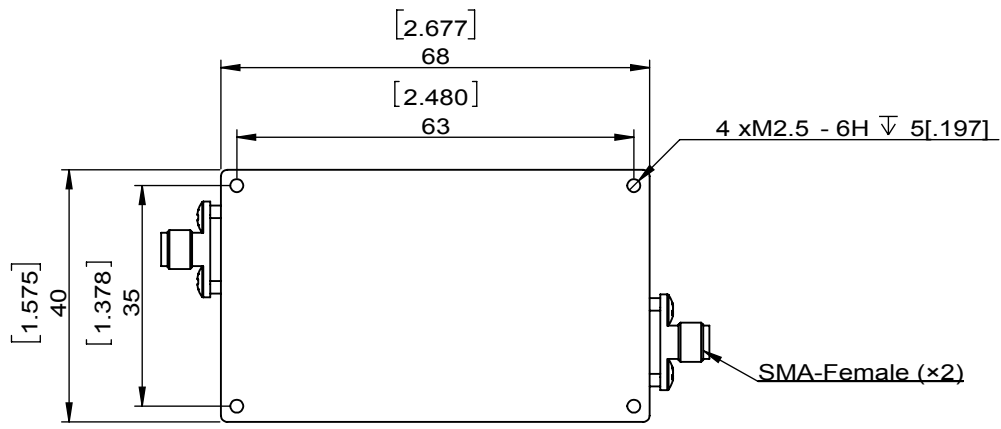

This document is the property of JQL Electronic Inc. It cannot be copied, duplicated, used for manufacturing purposes or communicated to third party as a whole or partly, without the written consent of JQL Electronic Inc.

1		2		3		4		5		6	
Document No.		QR4-700-T-003		REV.		DESCRIPTION		REVISOR		DATE	
REV.		A/0		0				YL.Chen		11.25.2019	
								HC.Qiu			

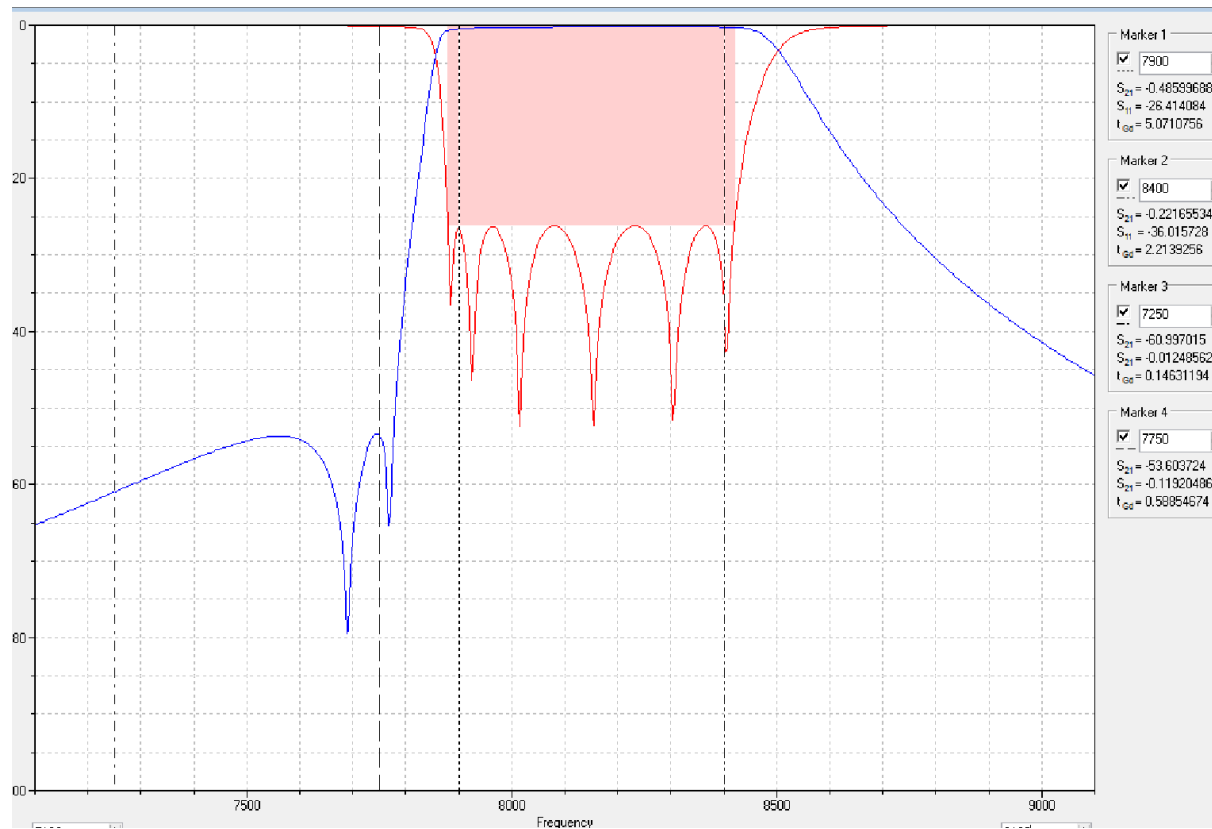

JQL JQL Electronic Inc				
MATERIAL:		DWG NO:		
Silver Plating		JFCB7900T8400SF-B		
SURFACE TREATMENT:		DWG BY:	YL.Chen	11.25.2019
Filter		CHK'D BY:		SCALE
		APPV'D BY:		1:1
		Unit:	Tolerance:	The First:
		mm[inch]	Liner: ±0.25	
			Anguar: ±0.5°	A4



This document is the property of JQL Electronic Inc. It cannot be copied, duplicated, used for manufacturing purposes or communicated to third party as a whole or partly, without the written consent of JQL Electronic Inc.