

1		2		3		4		5		6	
Document No.	QR4-700-T-003	REV.	A/0	REV.	DESCRIPTION	REVISOR	DATE	APPROVED			
		0		YL.Chen	12.19.2019	HC.Qiu					

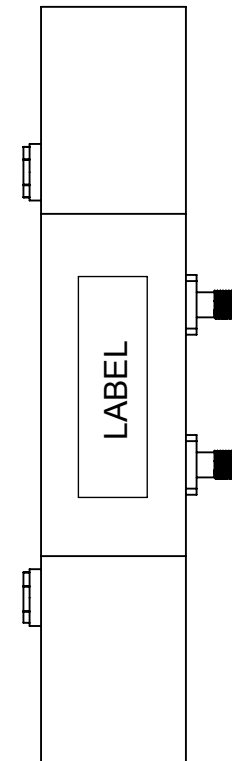

JQL JQL Electronic Inc				
MATERIAL:		DWG NO: JFCB14K4T15K4SMP		
SURFACE TREATMENT: Silver Plating		DWG BY:	YL.Chen	12.19.2019
DESCRIPTION: Filter		CHK'D BY:		SCALE
		APPV'D BY:		1:1
		Unit: mm[inch]	Tolerance: Liner: ±0.25 Anguar: ±0.5°	The First:
				A4

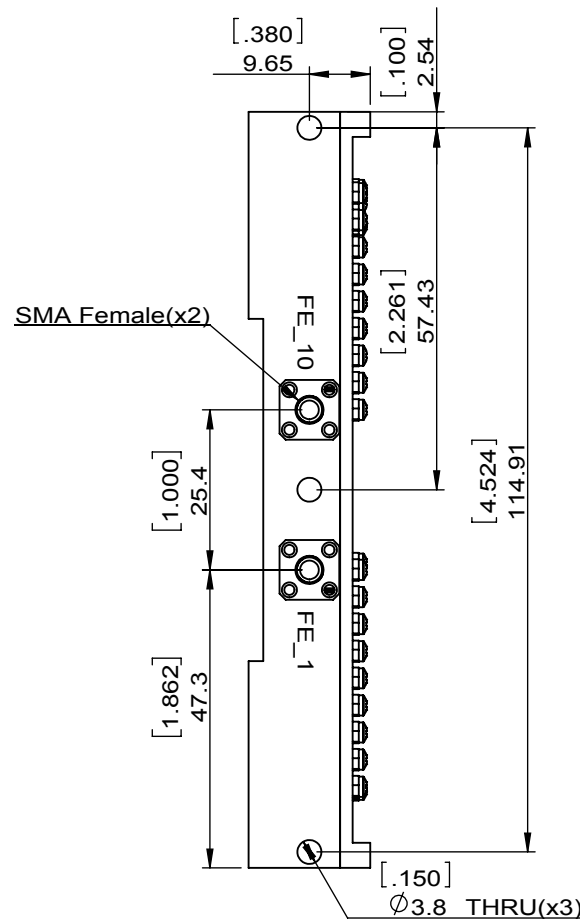
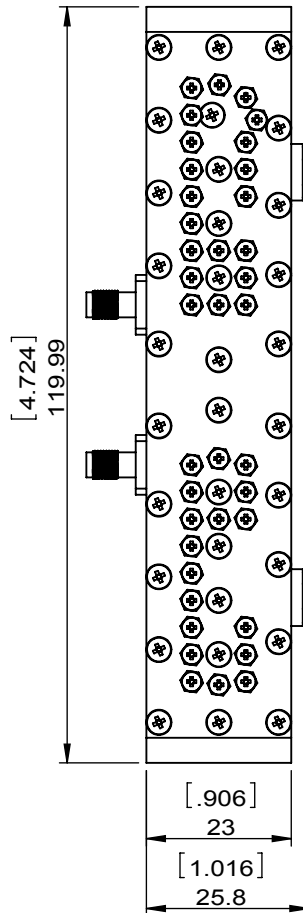
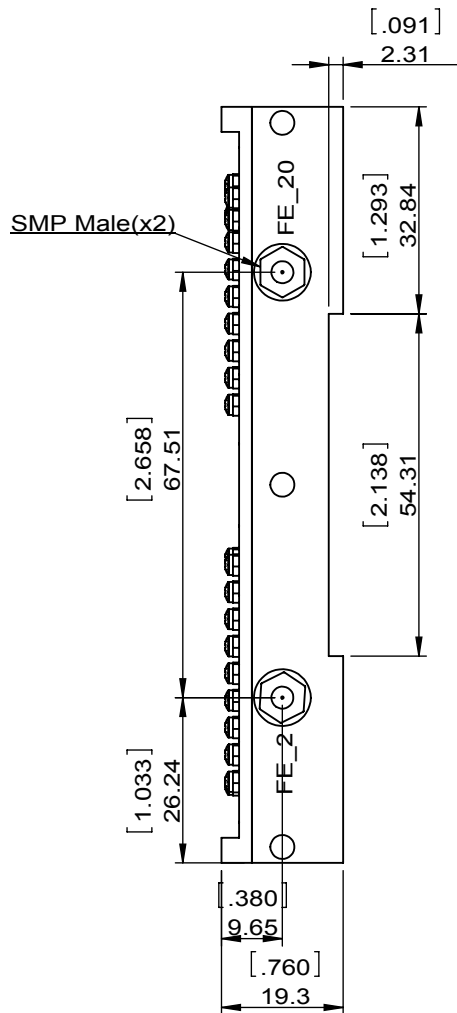

This document is the property of JQL Electronic Inc. It cannot be copied, duplicated, used for manufacturing purposes or communicated to third party as a whole or partly, without the written consent of JQL Electronic Inc.

WEIGHT:

1		2		3		4		5		6	
Document No.	QR4-700-T-003					REV.	DESCRIPTION	REVISOR	DATE	APPROVED	
REV.	A/0					0		YL.Chen	12.19.2019	HC.Qiu	

ITEM	SPECIFICATION	
	Filter 1	Filter 2
Pass Band(GHz)	14.4~14.83	15.15~15.35
Insertion Loss(dB)	1.5 Max(Over temp. range)	
Return Loss(dB)	14 Min	
In Band Ripple(dB)	0.6 p.t.p Max	
Group Delay Variation(nS)	1.5 p.t.p Max (Within any 100MHz band)	
Rejection(dBc)	15 Min@14.99GHz 30 Min@13.0~14.0GHz 60 Min@15.15~15.35GHz	15 Min@14.99GHz 30 Min@16.0~16.5GHz 60 Min@14.4~14.83GHz
Impedance(Ω)	50	
Power Handling(mW)	100 Max@50000 Feet	
Vibration Operational(Grms) Vibration Endurance(Grms)	8(10~2000Hz) 18(10~2000Hz)	15(10~2000Hz)
Shock(G)	20G 11msec saw tooth	
Temperature Range(°C)	-40~+85	
Connector	Port FE_1:SMA-Female Port FE_2:SMP-Male	Port FE_10:SMA-Female Port FE_20:SMP-Male
Environmental	Operational mode -95% relative humidity Non operational mode -95% Relative humidity Long storage -60% relative humidity	

JQL JQL Electronic Inc				
MATERIAL:		DWG NO: JFCB14K4T15K4SMP		
SURFACE TREATMENT: Silver Plating		DWG BY:	YL.Chen	12.19.2019
DESCRIPTION: Filter		CHK'D BY:		SCALE
		APPV'D BY:		1:1
		Unit: mm[inch]	Tolerance: Liner: ±0.25 Anguar: ±0.5°	The First: 
				A4



This document is the property of JQL Electronic Inc.
It cannot be copied, duplicated, used for manufacturing purposes
or communicated to third party as a whole or partly,
without the written consent of JQL Electronic Inc.