

| | |
|--------------|---------------|
| 1 | 2 |
| Document No. | QR4-700-T-003 |
| REV. | A/0 |

| | | | | |
|------|-------------|----------|------------|----------|
| 4 | 5 | 6 | | |
| REV. | DESCRIPTION | REVISOR | DATE | APPROVED |
| 0 | | Hu.Jiang | 07.31.2020 | HC.Qiu |

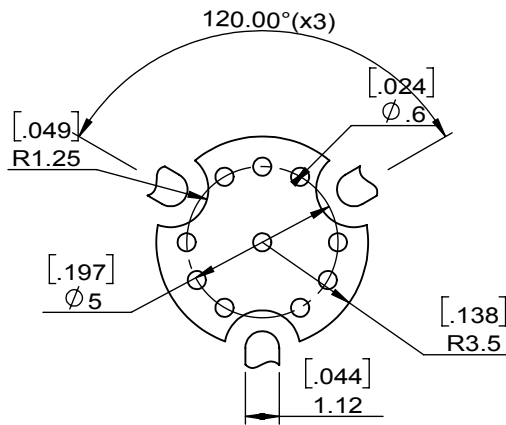

Copper Pattern

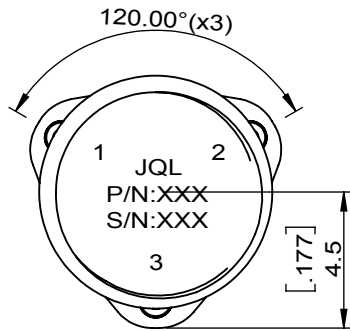
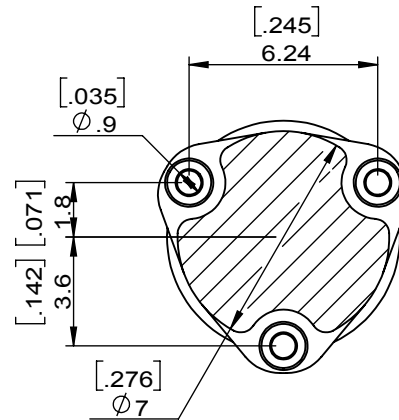
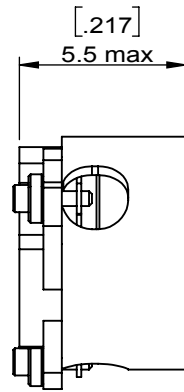
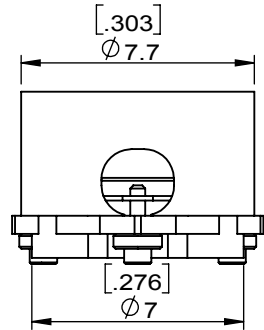
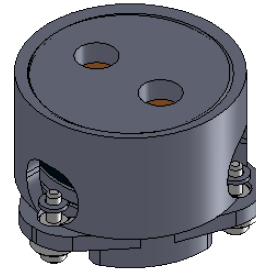
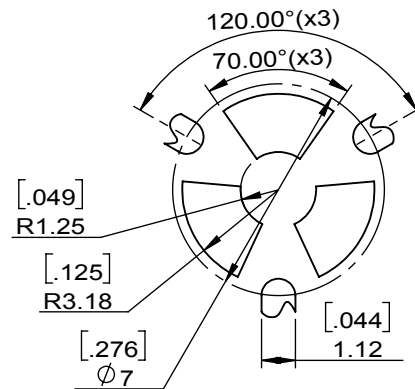

Soldermask Pattern

| SPECIFICATIONS | |
|---------------------------|-------------------------------|
| Part's Number | JCM2240T2300LM1R |
| Frequency(GHz) | 2.240~2.300 |
| Direction | CW |
| Insertion Loss(dB)MAX | 0.35@+25°C 0.40@-40+100°C |
| Isolation(dB)MIN | 22.0@+25°C 20.0@-40~+100°C |
| Return Loss(dB)MIN | 22.0@+25°C 20.0@-40~+100°C |
| 3rd IMD(dBc)MAX | -55@2X37dBm |
| Power FWD/REV/PK(Watt) | 10/10/- |
| Operating Temperature(°C) | -40~+100 |
| Storage Temperature(°C) | - |
| 2nd/3rd Harmonic(dBc) | |
| Additional Notes | |

| | | | | |
|---|--|------------------------------------|---|----------------|
| JQL JQL Technologies Corporation | | | | |
| MATERIAL: STEEL | | DWG NO: JCM2240T2300LM1R | | |
| SURFACE TREATMENT: SILVER PLATING | | DWG BY: | Hu.Jiang | 07.31.2020 |
| DESCRIPTION: SMT CIRCULATOR | | CHK'D BY: | | SCALE |
| | | APPV'D BY: | | 4:1 |
| | | Unit: mm[inch] | Tolerance: Liner: ±0.25 Anguar: ±0.5° | The First: |
| | | | | A4 |



This document is the property of JQL Technologies Corporation. It cannot be copied, duplicated, used for manufacturing purposes or communicated to third party as a whole or partly, without the written consent of JQL Technologies Corporation.

WEIGHT:

SHEET 1 OF 1