

1		2		3		4		5		6			
Document No.	QR4-700-T-003	REV.	A/0	REV.	0	DESCRIPTION		REVISOR	X.S	DATE	10.20.2022	APPROVED	HC.Qiu

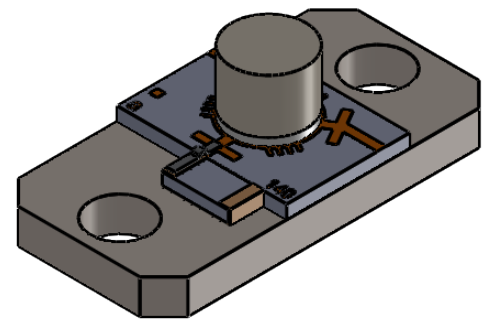

ITEM	SPEC
Frequency Rang(MHz)	13.000~15.000
Direction	CW
Insertion Loss(dB)	0.6 Max
Return Loss(dB)	16.6 Min
Isolation(dB)	20 Min
Power Forward(W)	2
Operating Temperature(°C)	-55~+85
Additional Notes	-

- Notes:
1. Mounting: Do not heat above: 130°C.
 2. RoHS and REACH compliant.
 3. Tuning conductor (97In3Ag) optional location and configuration determined by vendor.
 4. Humidity 5 to 95% non-condensing.
 5. Max temperature during welding process: +350°C @ 25 msec.

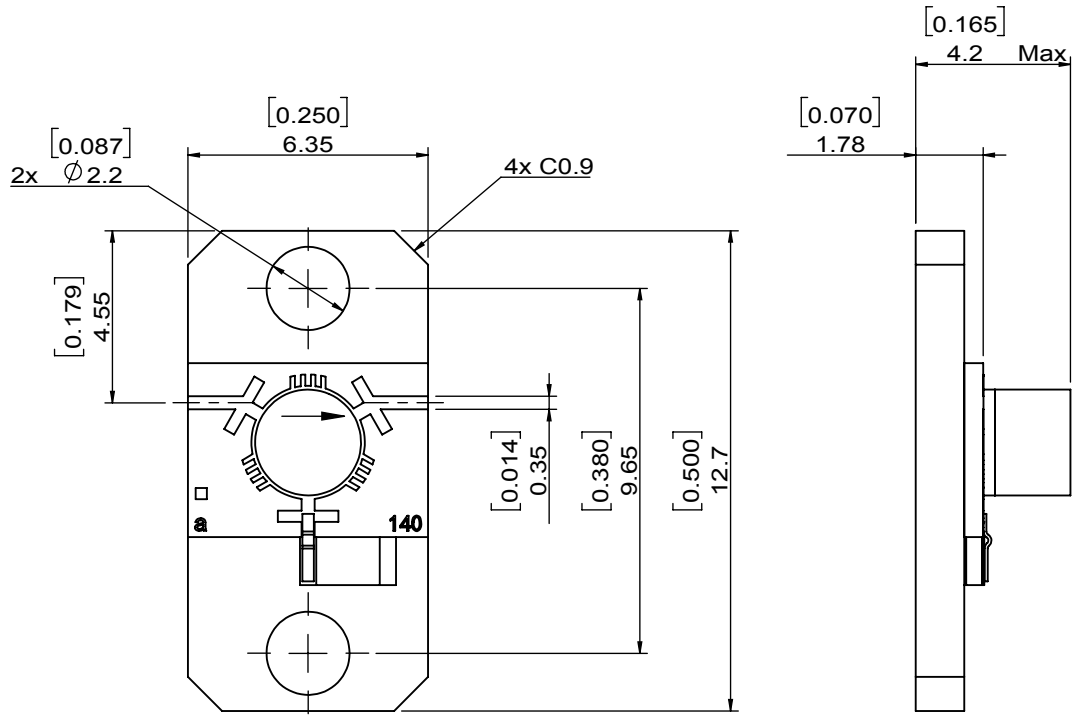

This document is the property of JQL Technologies Corporation. It cannot be copied, duplicated, used for manufacturing purposes or communicated to third party as a whole or partly, without the written consent of JQL Technologies Corporation.

JQL JQL Technologies Corporation

MATERIAL: -	DWG NO: 2IMC-14-1-BW14.29			
SURFACE TREATMENT: -	DWG BY:	X.S	10.20.2022	SCALE
	CHK'D BY:			
DESCRIPTION: Microstrip Isolator	APPV'D BY:			4:1
	Unit: mm[inch]	Tolerance: Liner: ±0.09 Anguar: ±0.5°	The First:	A4