

1		2		3		4		5		6			
Document No.	QR4-700-T-003	REV.	A/0	REV.	0	DESCRIPTION		REVISOR	X.S	DATE	05.16.2022	APPROVED	HC.Qiu

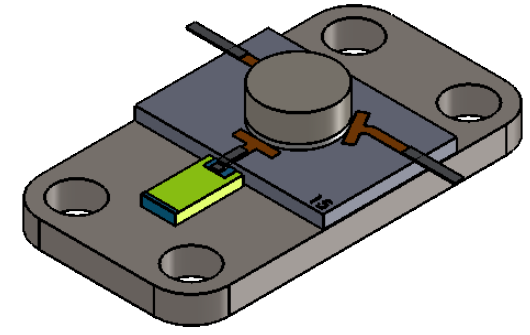

ITEM	SPEC
Frequency Rang(GHz)	14.500~15.600
Direction	CW
Insertion Loss(dB)	0.50 Max
Return Loss(dB)	19.0 Min
Isolation(dB)	20.0 Min
Power FWD/REV/PK(W)	10/1/-
Operating Temperature(°C)	-30~+70
Additional Notes	-

- Notes :
1. RoHS and REACH compliant.
 2. Humidity 5 to 95% non-condensing.
 3. Tabs : Ag plated Cu foil ribbon.
 4. Suitable for soldering (230 to 250°C @ 5sec) or ultrasonic welding (Max temperature during welding process : +350°C @ 25 msec.)

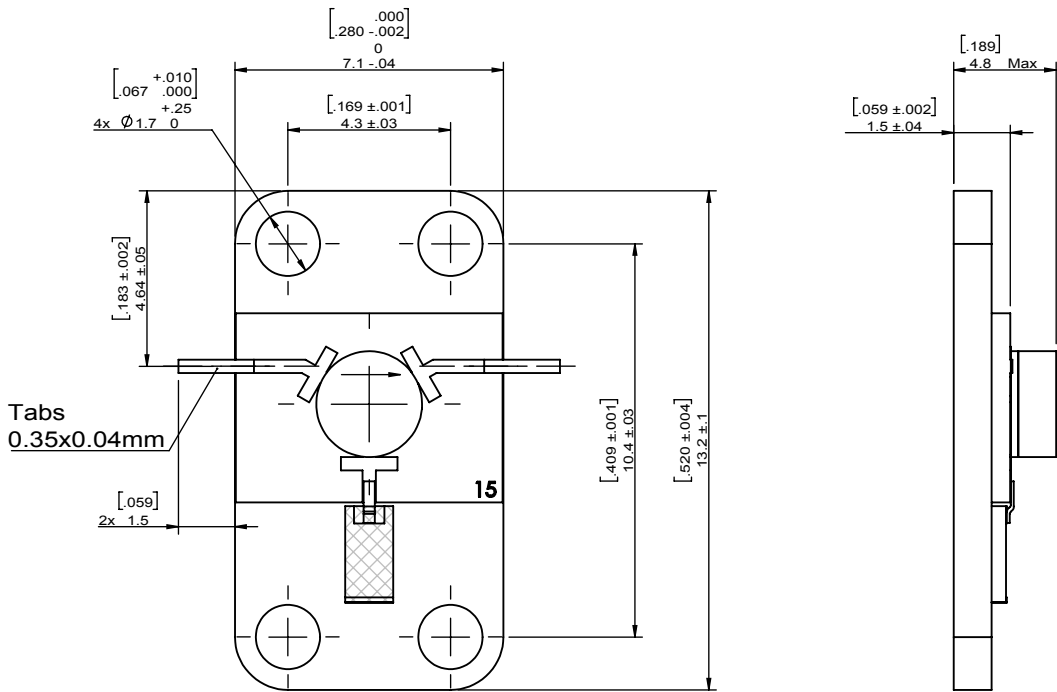

This document is the property of JQL Technologies Corporation. It cannot be copied, duplicated, used for manufacturing purposes or communicated to third party as a whole or partly, without the written consent of JQL Technologies Corporation.

JQL JQL Technologies Corporation

MATERIAL: -	DWG NO: 2IMC-14.8-1TS-15.05BW7.31			
SURFACE TREATMENT: -	DWG BY:	X.S	05.16.2022	SCALE
	CHK'D BY:			
DESCRIPTION: MICROSTRIP ISOLATOR	APPV'D BY:			5:1
	Unit: mm[inch]	Tolerance: Liner: ±0.25 Anguar: ±0.5°	The First:	A4