

1		2		3		4		5		6	
Document No.	QR4-700-T-003	REV.	A/0	REV.	DESCRIPTION	REVISOR	DATE	APPROVED			
				0		X.S	09.01.2022	HC.Qiu			

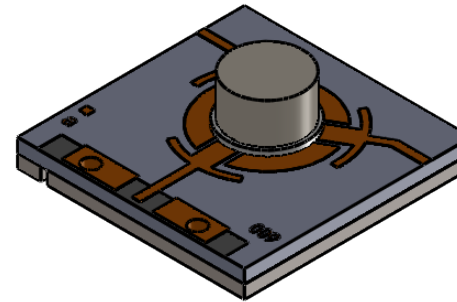
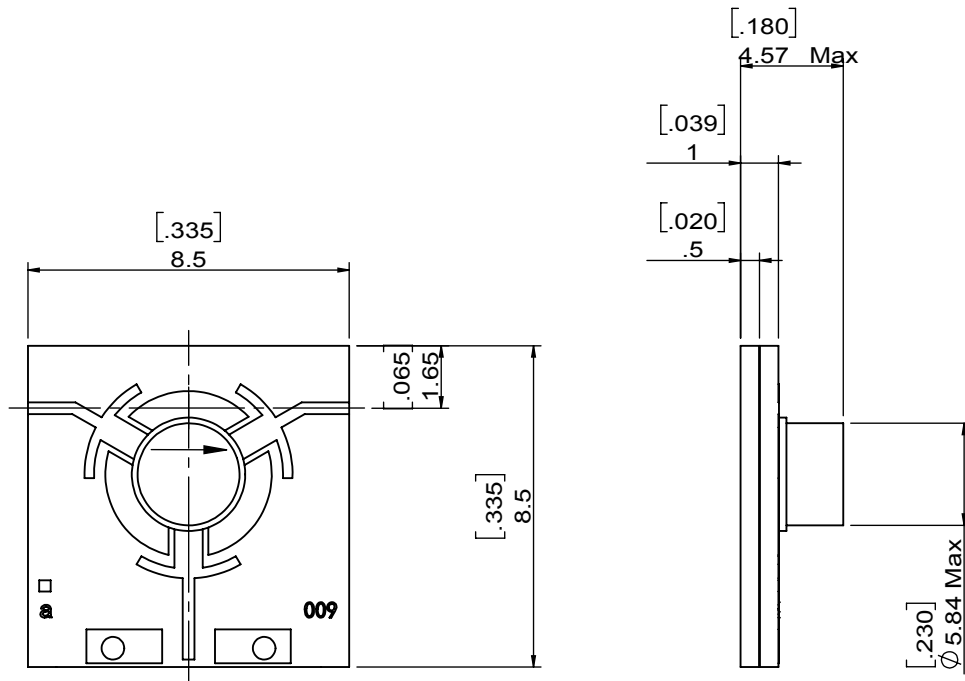

ITEM	SPEC
Frequency Rang(GHz)	8.500~9.600
Direction	CW
Insertion Loss(dB)	0.5 Max
Return Loss(dB)	19 Min
Isolation(dB)	20 Min
Power(W)	1
Operating Temperature(°C)	-40~+85
Additional Notes	-

Notes :

1. All marking to be on shipping containers only.
2. RoHS Compliant.
3. Do not heat above 130°C.
4. Humidity 5 to 95% non-condensing.
5. Maximal temperature during welding process : +350°C @ 25 msec.



This document is the property of JQL Technologies Corporation. It cannot be copied, duplicated, used for manufacturing purposes or communicated to third party as a whole or partly, without the written consent of JQL Technologies Corporation.

<b>JQL JQL Technologies Corporation</b>				
<b>MATERIAL:</b>		<b>DWG NO:</b>		
-		2W8NK-1		
<b>SURFACE TREATMENT:</b>		DWG BY:	X.S	09.01.2022
-		CHK'D BY:		SCALE
<b>DESCRIPTION:</b>		APPV'D BY:		5:1
MICROSTRIP ISOLATOR		Unit:	Tolerance:	The First:
		mm[inch]	Liner: ±0.25	
			Anguar: ±0.5°	A4