

1		2		3		4		5		6	
Document No.		QR4-700-T-003		REV.		DESCRIPTION		REVISOR		DATE	
REV.		A/0		0				J.Z		06.15.2022	
										APPROVED	
										HC.Qiu	

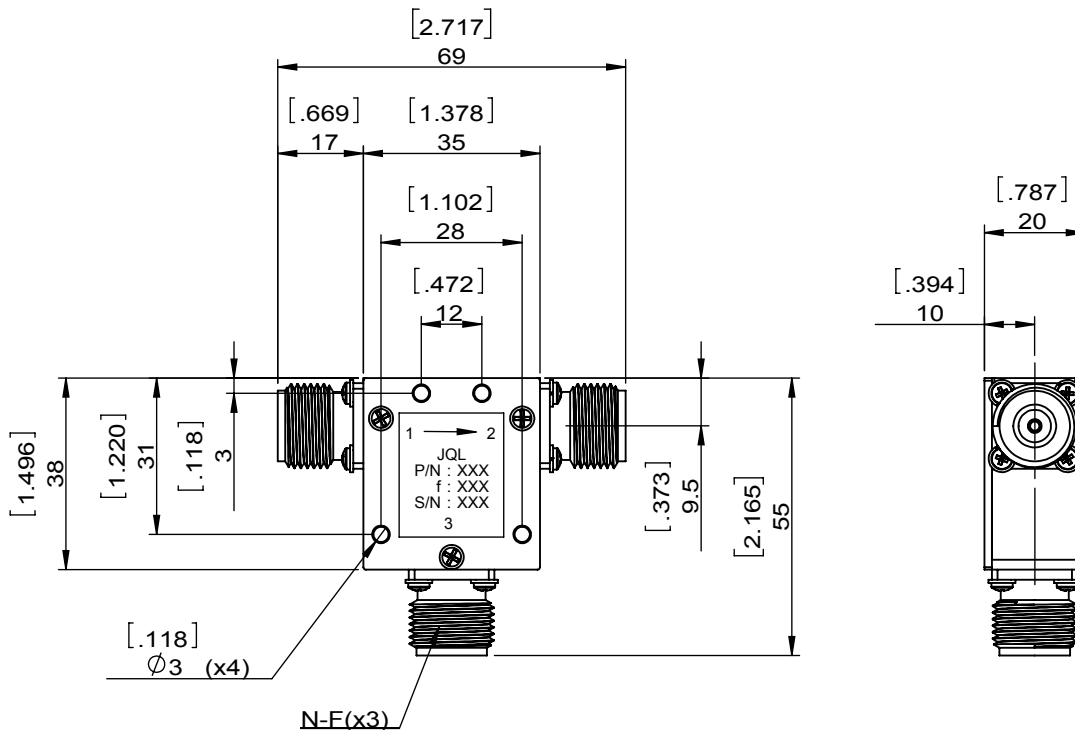

SPECIFICATIONS	
Part's Number	JCC0850T0870NF
Frequency(GHz)	0.850~0.870
Direction	CW
Insertion Loss(dB)MAX	0.30
Isolation(dB)MIN	20.0
Return Loss(dB)MIN	20.0
3rd IMD(dBc)MAX	-65@2x150W
Power FWD/REV/PK(Watt)	150/150/-
Operating Temperature(°C)	-20~+75
Storage Temperature(°C)	-
2nd/3rd Harmonic(dBc)	-
Termination/Attenuator(Watt/dB)	-
Tab(W×LG×THK)(mm[Inch])	-
Additional Notes	-

JQL JQL Technologies Corporation				
MATERIAL: STEEL		DWG NO: JCC0850T0870NF		
SURFACE TREATMENT: NICKEL PLATING		DWG BY:	J.Z	06.15.2022
DESCRIPTION: COAX CIRCULATOR		CHK'D BY:		SCALE
		APP'V'D BY:		2:3
		Unit: mm[inch]	Tolerance: Liner: ±0.25 Anguar: ±0.5°	The First:
				A4

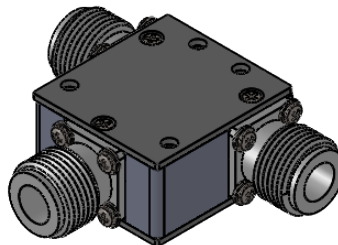
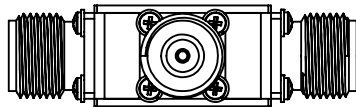

This document is the property of JQL Technologies Corporation. It cannot be copied, duplicated, used for manufacturing purposes or communicated to third party as a whole or partly, without the written consent of JQL Technologies Corporation.