

| | | | | | | | | | | | |
|--------------|---------------|------|-----|------|-------------|---------|------------|----------|--|---|--|
| 1 | | 2 | | 3 | | 4 | | 5 | | 6 | |
| Document No. | QR4-700-T-003 | REV. | A/0 | REV. | DESCRIPTION | REVISOR | DATE | APPROVED | | | |
| | | | | 0 | | J.Z | 06.17.2022 | HC.Qiu | | | |

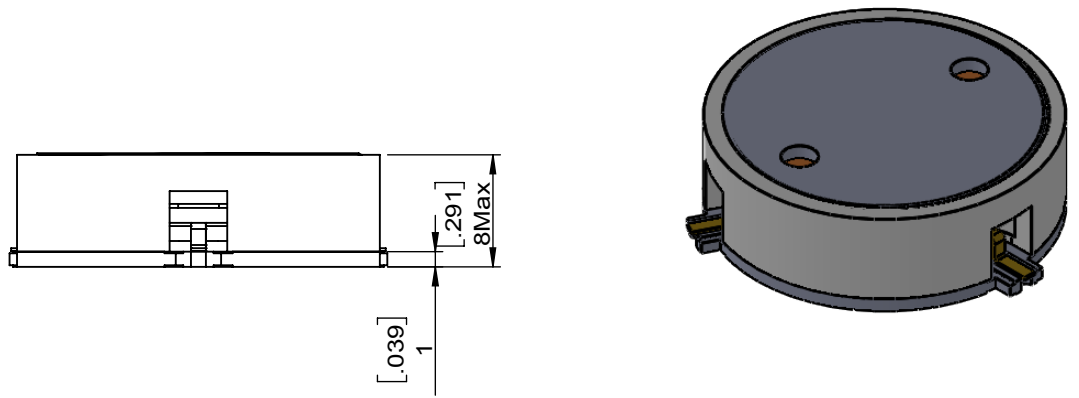

| SPECIFICATIONS | |
|---------------------------------|------------------|
| Part's Number | JCM1030T1090S5RC |
| Frequency(GHz) | 1.030~1.090 |
| Direction | CCW |
| Insertion Loss(dB)MAX | 0.35 |
| Isolation(dB)MIN | 21.0 |
| Return Loss(dB)MIN | 20.0 |
| 3rd IMD(dBc)MAX | - |
| Power FWD/REV/PK(Watt) | 5050/1000 |
| Operating Temperature(°C) | -55~+50 |
| Storage Temperature(°C) | - |
| 2nd/3rd Harmonic(dBc) | - |
| Termination/Attenuator(Watt/dB) | - |
| Tab(W×LG×THK)(mm[Inch]) | - |
| Additional Notes | - |

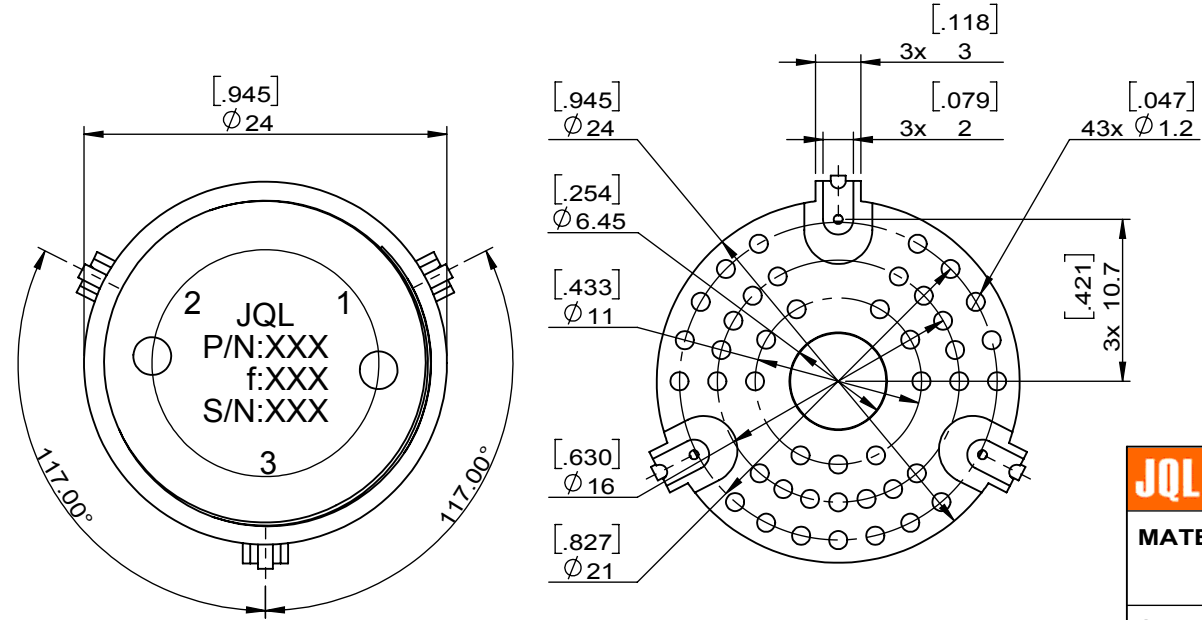

| | | | | |
|---|--|------------------------------------|---|----------------|
| JQL JQL Technologies Corporation | | | | |
| MATERIAL: STEEL | | DWG NO: JCM1030T1090S5RC | | |
| SURFACE TREATMENT: NICKEL PLATING | | DWG BY: | J.Z | 06.17.2022 |
| DESCRIPTION: SMT CIRCULATOR | | CHK'D BY: | | SCALE |
| | | APP'V'D BY: | | 2:1 |
| | | Unit: mm[inch] | Tolerance: Liner: ±0.25 Anguar: ±0.5° | The First: |
| | | | | A4 |



This document is the property of JQL Technologies Corporation. It cannot be copied, duplicated, used for manufacturing purposes or communicated to third party as a whole or partly, without the written consent of JQL Technologies Corporation.