

1		2		3		4		5		6	
Document No.	QR4-700-T-003	REV.	A/0	REV.	DESCRIPTION	REVISOR	DATE	APPROVED			
				0		J.Z	10.10.2022	HC.Qiu			

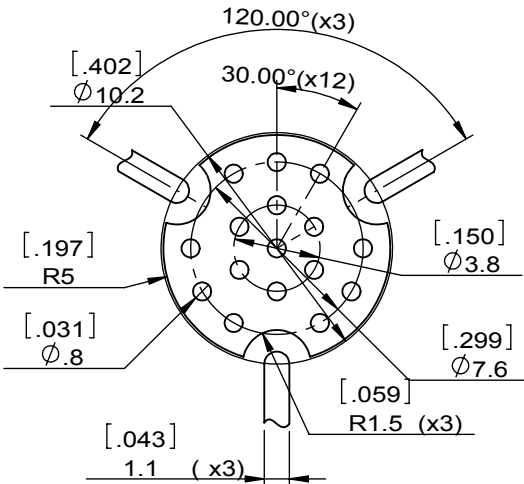

Copper Pattern

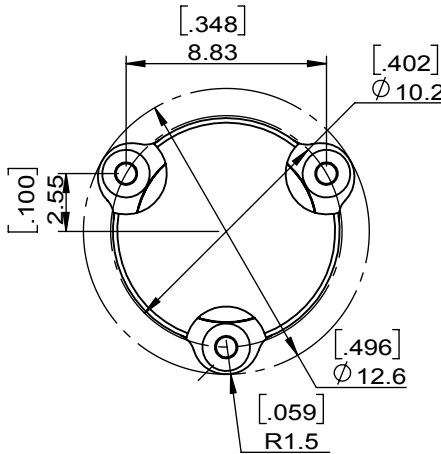
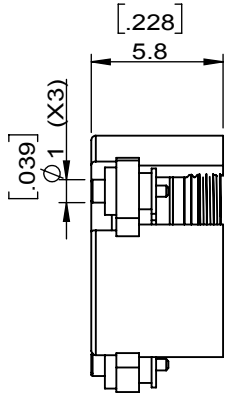
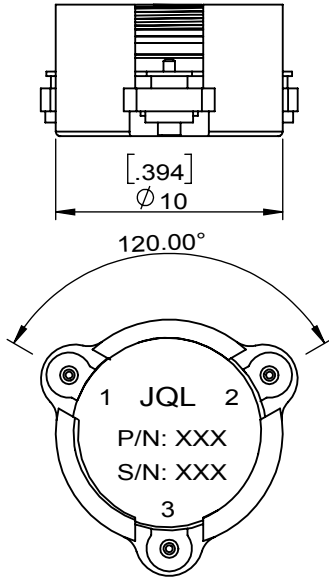
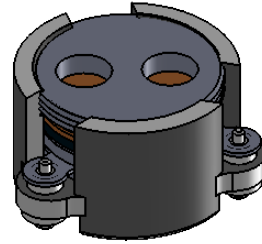
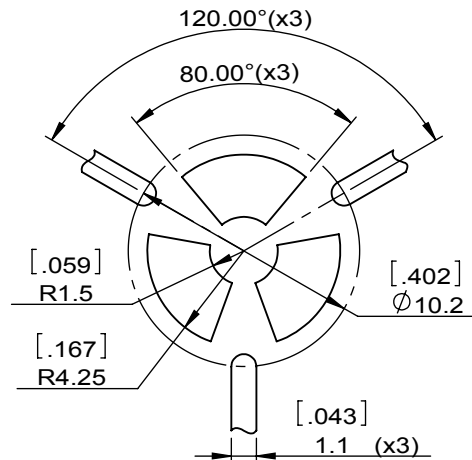

Soldermask Pattern

SPECIFICATIONS	
Part's Number	JCM3100T3500PT5R
Frequency(GHz)	3.100~3.500
Direction	CW
Insertion Loss(dB)MAX	0.30@+25°C 0.35@-40~+85°C
Isolation(dB)MIN	22.0@+25°C 20.0@-40~+85°C
Return Loss(dB)MIN	22.0@+25°C 20.0@-40~+85°C
3rd IMD(dBc)MAX	-
Power FWD/REV/PK(Watt)	-/-/50
Operating Temperature(°C)	-40~+85
Storage Temperature(°C)	-
2nd/3rd Harmonic(dBc)	-
Additional Notes	

JQL JQL Technologies Corporation.				
MATERIAL: STEEL		DWG NO: JCM3100T3500PT5R		
SURFACE TREATMENT: SILVER PLATING		DWG BY:	J.Z	10.10.2022
DESCRIPTION: SMT CIRCULATOR		CHK'D BY:		SCALE
		APPV'D BY:		3:1
Unit: mm[inch]		Tolerance: Liner: ± 0.25 Anguar: $\pm 0.5^\circ$	The First:	A4



This document is the property of JQL Technologies Corporation. It cannot be copied, duplicated, used for manufacturing purposes or communicated to third party as a whole or partly, without the written consent of JQL Technologies Corporation.